

UREG

Regency Urinal

Installation Guide

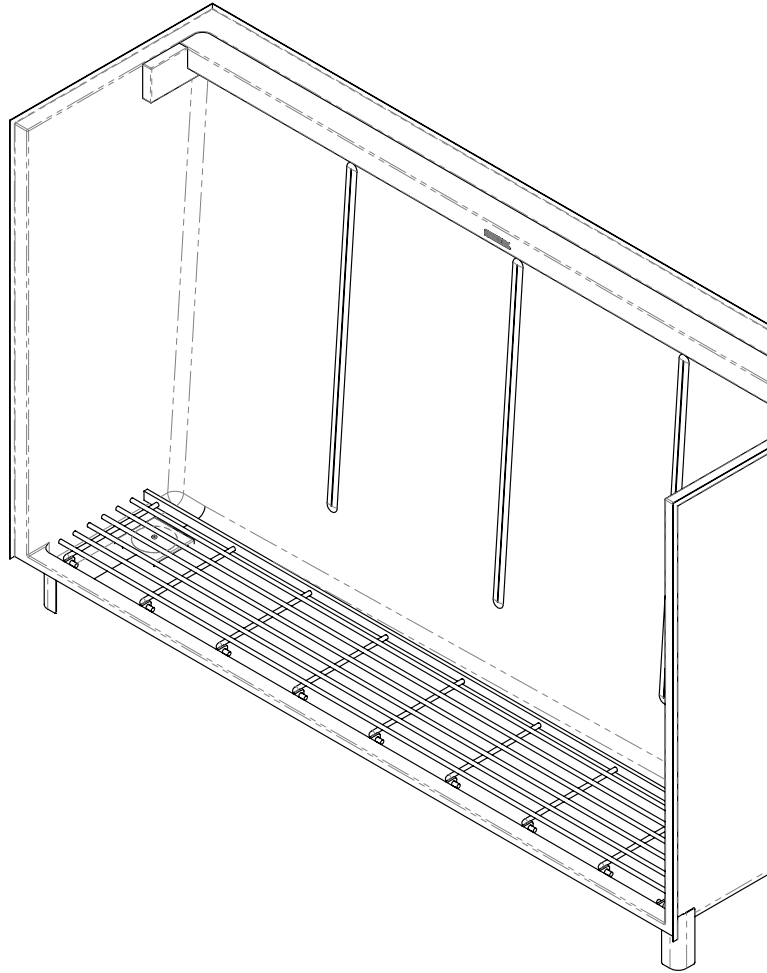

MELBOURNE

Britex Place Mira Crt
Bundoora VIC 3083
t (03) 9466 9000
e vic@britex.com.au

SYDNEY

16 Northumberland Drv
Taren Point NSW 2229
t (02) 9531 2100
e nsw@britex.com.au

PERTH

Unit 1/8 Principal Link
Mallaga WA 6090
t (08) 9249 5464
e wa@britex.com.au

BRISBANE

19 Hanilla St
East Brisbane QLD 4169
t (07) 3363 2400
e qld@britex.com.au

ADELAIDE

The Britex Group
SA State Office
t 1300 764 744
e sa@britex.com.au

IMPORTANT

ALL SERVICE TO BE PERFORMED BY AN AUTHORISED SERVICE PERSON

Installation of this unit must be in accordance with AS/NZS 3500.2, the PCA and the local regulatory requirements. Water and/or electrical supply conditions must comply to national or state requirements and standards. Failure to comply shall void the product warranty and may affect the performance of the product. For further support and after-sales care, please contact Britex.

WARNING

WHEN INSTALLATION IS COMPLETE, ENSURE THESE INSTRUCTIONS REMAIN INSIDE THE PLASTIC BAG PROVIDED WITH THE UNIT FOR FUTURE REFERENCE

About

The BRITEX Regency Urinal is the most hygienic stainless-steel urinal in the BRITEX hinged grate range. With the same extensive list of benefits as the Sanistep urinal, the Regency features protecting side walls that may otherwise be exposed to water/fluid damage after being installed for an extended period. The Regency is particularly suited to schools, night clubs and public amenity buildings. WaterMark and WELS certified as required by plumbing regulations and government legislation.

Preparation and Completion Notes

Britex urinals are approved for use as per the accompanying certifications and can be coupled with cisterns, flush valves & sensor flushing systems according to specific model requirements. It is the installer's responsibility to ensure that the urinal is installed in accordance and to the regulations of the residing governing authority and all applicable plumbing code regulations. Britex Floor Mounted Urinal's are fitted with a water spreader incorporating options of rear or top mounted inlets (38mm (1.5")). As a standard practice 38mm (1.5") inlets will be provided unless 25mm (1") inlets are specifically requested.

1. 38mm (1.5") Inlets: Are typically supplied to urinals that are to be flushed with cisterns or flush valves. The urinals inlet supply fitting consists of a nylon adaptor and flanged nut to suit 38mm (1.5") flush pipe tube, (copper, stainless steel etc). Alternatively, 40mm DWV PVC pipe can be used by substituting the urinal nylon flange nut for a DWV PVC Adaptor Female Iron 40mm. If a flushing device is utilised with a smaller supply line, then the nylon inlet adaptor can be reduced with appropriate fittings if the flushing device and supply requirements are in accordance with the urinal specifications.

A Discharge waste outlet vary dependent on nominated size received on order placement, but generally consist of 50mm (2'), 75mm (3") & 100mm (4") dependent on local plumbing regulations.

As the urinal is to be fixed to the rear wall, ensure that the substructure will provide sufficient support to the urinal. Complete any reinforcement works as necessary and provide noggins where required. Use appropriate anchors suitable for use with the substructure to fix the urinal to the wall surface.

Floor mounted urinals can be recessed and made flush with the finished floor level or mounted directly onto the floor (Step Up). If the urinal is to be recessed, refer to the urinal trench dimensions within this document.

Preparation and Completion Notes

The preparation of a slurry bed is part of the bedding down process for all urinal installations inclusive of floor mounted and recessed urinals. Additional works, structural conformance, water proofing etc. may be required to the substructure and should be investigated and approved by the appropriate authorities. All preliminary works should be completed prior to the installation of the urinal.

Protect the surface of the product during the installation process. Do not remove any PVC coatings that may have been applied to the surface until the product has been commissioned and ready to be used.

Recommended Flushing Devices

	Rear Water Entry				Top Water Entry
	FSM1 - Smart Saniflush Sensor - Electronic	FSM2 - Smart Saniflush Sensor - Electronic	FFV-E1 - Single Piezo Button Electronic Flush Valve	FIW-SP45 - Pneumatic In Wall Cistern Single Push Button	FCP - Pull Chain Cistern
Urinal Length	Single Solenoid Up to 1800mm	Dual Solenoid 1800mm-3600mm	Up to 1800mm	Up to 1800mm	Up to 1800mm
UREG	✓	✓	✓	✓	

UREG Drawing

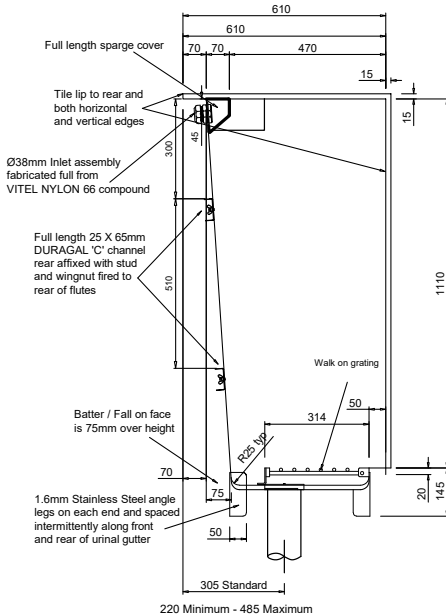
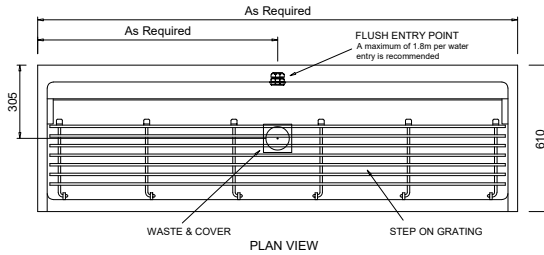
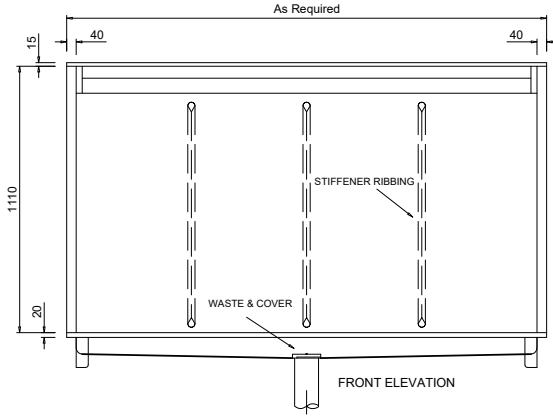

Recessed Model Shown
Floor Mounted Model
Includes Front Panel

Installation Instructions

1. Prior to installing the urinal ensure the substructure has been prepared to accommodate all required services inclusive of supply lines, sanitary discharge connections and set down trench for recessed urinals. Service locations are provided on the applicable model diagrams within this document.

a. Rear inlet supply connections will require the provision of a permanent front or rear access panel within the wall face to be provided above each inlet connection, or alternatively, a temporary cavity that can be sealed on the completion of connections and commissioning.

b. Sanitary discharge connections should be terminated at a height 20mm below the underside of the urinal gutter. Terminating the discharge pipe with a pan collar fitted with an internal rubber gasket is recommended.

2. On completion of the rough in process, place the urinal into position, ensuring the urinal waste outlet spigot is in line and enters the discharge pipe without obstruction and the urinal sits stable and flush to the rear wall.

3. Once in position and particularly with recessed urinal installations, preliminary checks and adjustments should be carried out to ensure that the urinal is level and at the correct height.

a. Use the top of the urinal gutter's front fascia edge to determine the level and height of the urinal, taking into consideration and allowing for any final floor finishes, tiles etc.

b. Check and ensure that the horizontal top and side edges are level and that the front vertical edges are plumb.

c. Use plastic packers under the feet or directly under the trough on USAN urinals to make level or raise the urinal to the correct height. Do not use metal packers. Once satisfied that the urinal is level, a container of water can be poured into the urinal gutter to ensure that it adequately drains to the waste outlet.

4. Take note and mark any applicable reference points, then, remove the urinal from the set position.

5. Mix a mortar or non-shrink grout slurry to a soft malleable consistency. The slurry mixture should hold firm in a mound yet be pliable enough to spread throughout the underside cavity of floor mounted urinals. For recessed urinals the slurry will be contained within the trench cavity and can be of a softer consistency allowing it to overflow when the urinal is placed into position.

6. Place the urinal back into position ensuring any packers used within the dry run are correctly arranged and remain in location and that the waste outlet spigot is seated within the discharge pipe.

a. It is critical to ensure that the slurry has not raised the base of the gutter or the formation of the outlet that will prevent adequate draining.

b. Bed the urinal down to ensure it is seated correctly by applying even pressure to the urinal. Even pressure can be applied to the urinals gutter, by standing on a length of timber placed into the trough. Placing your foot on the outlet cover and applying pressure will also ensure the outlet is correctly seated.

c. The urinal must be fully supported to alleviate any flexing. No air pockets should be present.

d. Weighted timbers can be placed within the trough to maintain the formation of the trough.

Installation Instructions

- 7.** Recheck all levels and drainage capability (refer to step 3 procedures) and make any final adjustments as necessary.
- 8.** Once satisfied that the urinal is perfectly level and the gutter base and outlet sufficiently drain, drill through the tiled edge at the back and sides of the urinal and insert appropriate fixings into studs or noggins at no less than 600mm (23.6”) centres.
- 9.** Remove and dispose the overflow of excess slurry and clean away any spillage from the surface of the urinal with a damp cloth, taking care not to scratch any exposed stainless steel.
- 10.** Complete the connection of the flushing device to the urinal. The flushing device should then be tested and all connections checked for leaks.
- 11.** Perform a flush cycle to condition the weir sparge, followed by a second cycle to ensure that an adequate volume of water is being delivered to sufficiently flush the entire urinal face. Make any applicable adjustments to the volume of water, pressure or flow rates as necessary. Refer to the manufacturer’s installation and operation manuals for any flushing devices to be coupled with the urinal.
- 12.** On the completion of commissioning the urinal, and all associated plumbing and fixtures, the wall and floor coverings can now be completed. The perimeter of the urinal should then be sealed with an appropriate non-pickable sealer.
- 13.** Protect the urinal and do not remove the protective PVC coating while additional building works are being conducted. On completion of all building works and prior to functional use, the PVC coating should be removed, and the urinal cleaned as per the following cleaning and general maintenance instructions.

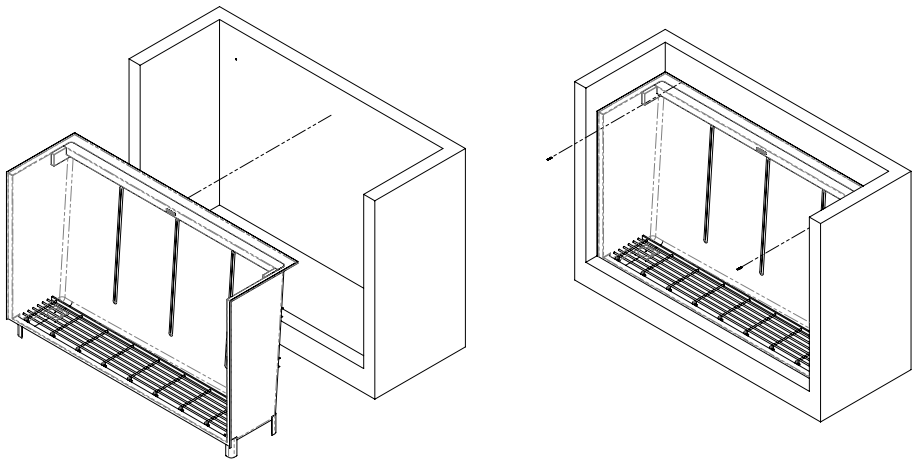

Recessed Urinal Trench Drawing

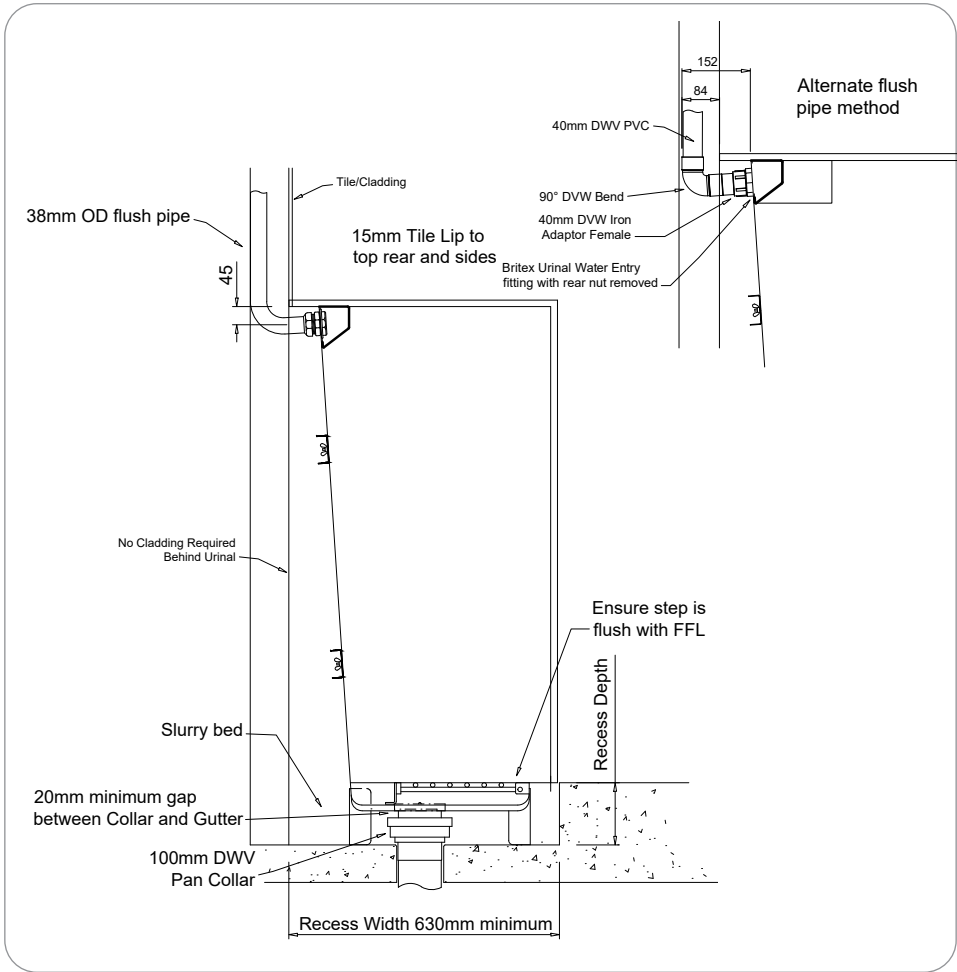

Recessed Urinal Trench Details

Urinal		Urinal Trench Dimensions (mm)	
Urinal Model	Urinal Foot Print	Trench Dimensions	Depth < 1M - 5M Long
UREG	L x W 610	L + 40 x W 630	150

Floor Mount Urinal Drawing

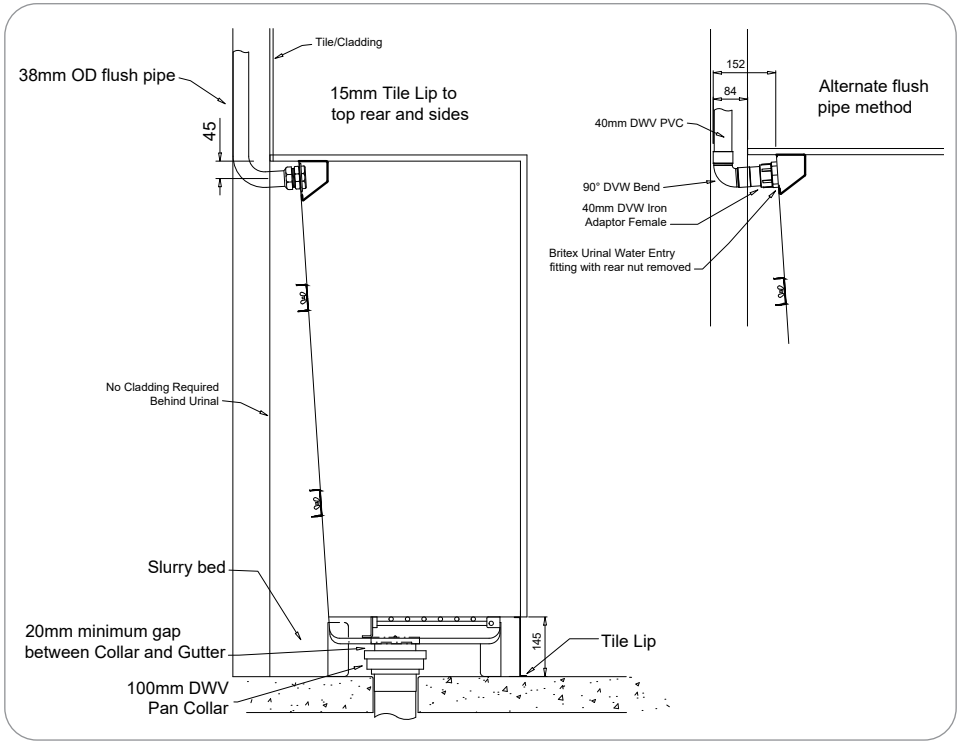

Top Entry Urinal Drawing

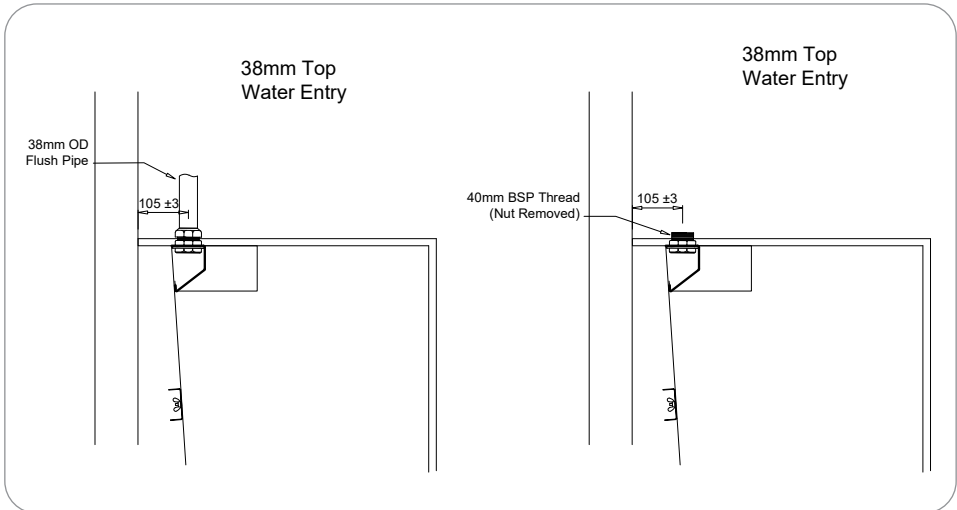

Spare Parts



72-05-0010

Spring Loaded Urinal Outlet Cover

Care and Maintenance

Cleaning: The coil at the front of the unit and the vents on the side must be kept clean from dust and lint. Regular checks of the unit should be conducted on a weekly basis and cleaning carried out as necessary by dusting with a soft brush and/or vacuuming. A damp cloth can be used to wipe the exterior cover down. Excessive build up of foreign material will result in poor ventilation, causing the compressor to overheat and drinking water to increase in temperature. High pressure hoses and water jets should never be used to clean chiller units.

Stainless steel products should be kept clean at all times. The secret to stainless steel's ability to maintain a high quality finish and promises of a long life expectancy is the invisible chromium-oxide film that sits on the surface and protects the steel beneath. To maintain this film it is essential that the surface remains clean and in constant contact with oxygen. If this film is penetrated (either by abrasion or chemically) and dirt, liquid, grime contaminants embed themselves in these micro chasms for an extended period of time, the chromiumoxide film will not be able to regenerate and the steel below will eventually become damaged and discoloured.

What we recommend for general cleaning and maintenance:

Cleaning Materials:

- A soft cloth
- A soft-bristled brush
- A natural or artificial sponge

Cleaning Solutions:

- Hand washing soap / soft water solution
- Mild soap / soft water solution
- White vinegar / soft water solution

It is recommended that general cleaning of stainless steel surfaces be carried out weekly, or as soon as a build up of surface media has been observed. To clean, simply wash stainless steel surfaces with, warm, diluted, mild soapy water using a cloth or soft bristled brush. Once all dirt, oil and grime is removed, rinse thoroughly with

clean water and wipe dry.

Do NOT - use a metal brush or steel wool to clean stainless steel. Ever. These tools will scratch the surface as well as potentially leave behind steel fragments that can go rusty and cause the stainless to discolour. Using these materials will void the warranty.

Do NOT - use scourers of any kind that have previously been used on ordinary steel. Microscopic steel fibers transferred onto stainless steel can cause considerable damage to the surface and will void the warranty.

Do NOT - use abrasive cleaning brushes, pads or agents on highly polished finishes

Do NOT use harsh cleaners that contain powerful acidic or alkaline chemicals such as hydrochloric acid and sodium hydroxide that will damage the surface. Any water coming into contact with stainless steel, particularly cleaning solutions, should have zero chloride content as even minute amounts can cause damage. Using these cleaners will void any product warranty.

Do NOT - use chlorinated sanitizers, cleansers or bleach of any kind. Using these substances will void the warranty. Despite some cleaners displaying the text, 'Suitable for Toilets and Urinals' this is more likely in reference to ceramic/vitreous China products and use of these cleaners can damage stainless steel and will void the warranty.

Do NOT - use brick cleaning liquids that contain hydrochloric acid anywhere near stainless. If cement needs to be removed from stainless (before it sets), a mixture of hot water and 25% vinegar or 10% phosphoric acid can be effective. Once cleaned, the surface should then be neutralised with dilute ammonia or sodium bicarbonate then rinsed and dried

Warranty

The BRITEX product is backed by our manufacturer's warranty available for download from our website at www.britex.com.au. We expressly warrant that the product is free from operational defects in workmanship and materials for the warranty period indicated on the schedule in the manufacturer's warranty. During the warranty period, BRITEX will repair or replace any defective products manufactured by BRITEX at no charge, provided that the terms of the manufacturer's warranty are followed.

This warranty is the only warranty given by BRITEX, and we expressly disclaim all other warranties, including but not limited to implied warranties of merchantability and fitness for a particular purpose. This warranty represents the sole and exclusive remedy for breach of warranty, and BRITEX shall not be liable for any incidental, special, or consequential damages, including lost profits, labor charges, delays, vandalism, negligence, fouling caused by foreign material, damage from adverse water conditions, chemical, electrical or any other circumstances beyond BRITEX's control.

This warranty shall be void if the product is abused, misused, improperly installed, maintained, or altered. By purchasing our product, you agree to these terms and conditions. We appreciate your business and look forward to providing you with high-quality products and services.



MELBOURNE
Britex Place Mira Crt
Bundoora VIC 3083
t (03) 9466 9000
e vic@britex.com.au

SYDNEY
16 Northumberland Drv
Taren Point NSW 2229
t (02) 9531 2100
e nsw@britex.com.au

PERTH
Unit 1/8 Principal Link
Malaga WA 6090
t (08) 9249 5464
e wa@britex.com.au

BRISBANE
19 Manilla St
East Brisbane QLD 4169
t (07) 3363 2400
e qld@britex.com.au

ADELAIDE
The Britex Group
SA State Office
t 1300 764 744
e sa@britex.com.au