

UR/URAM

Regal Urinal Pod

Installation Guide

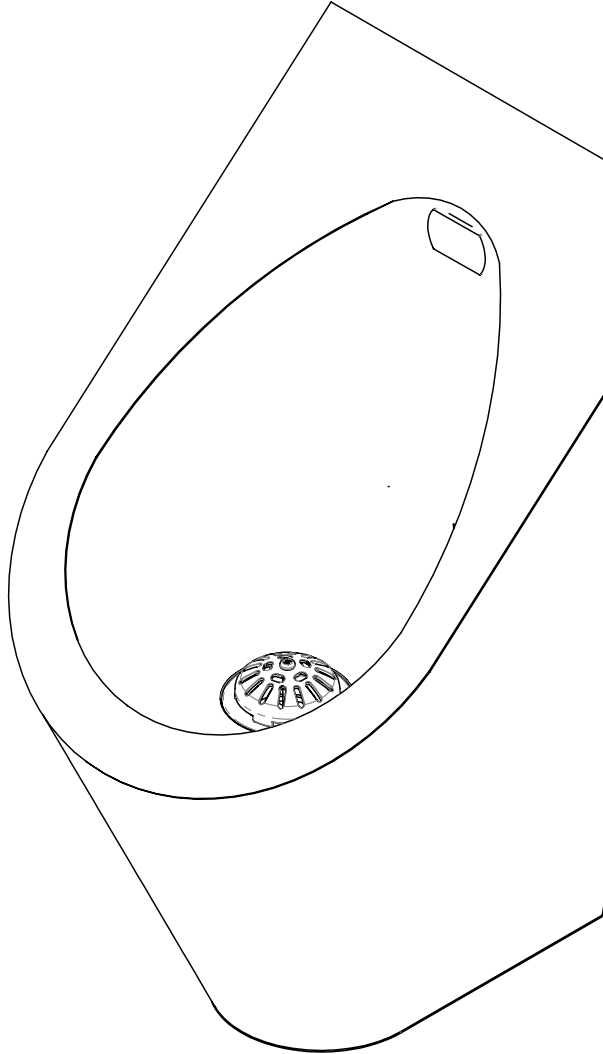

MELBOURNE

Britex Place Mira Crt
Bundoora VIC 3083
t (03) 9466 9000
e vic@britex.com.au

SYDNEY

16 Northumberland Drv
Taren Point NSW 2229
t (02) 9531 2100
e nsw@britex.com.au

PERTH

Unit 1/8 Principal Link
Mallaga WA 6090
t (08) 9249 5464
e wa@britex.com.au

BRISBANE

19 Manila St
East Brisbane QLD 4169
t (07) 3363 2400
e qld@britex.com.au

ADELAIDE

The Britex Group
SA State Office
t 1300 764 744
e sa@britex.com.au

IMPORTANT

ALL SERVICE TO BE PERFORMED BY AN AUTHORISED SERVICE PERSON

Installation of this unit must be in accordance with AS/NZS 3500.2, the PCA and the local regulatory requirements. Water and/or electrical supply conditions must comply to national or state requirements and standards. Failure to comply shall void the product warranty and may affect the performance of the product. For further support and after-sales care, please contact Britex.

WARNING

WHEN INSTALLATION IS COMPLETE, ENSURE THESE INSTRUCTIONS REMAIN INSIDE THE PLASTIC BAG PROVIDED WITH THE UNIT FOR FUTURE REFERENCE

About

The BRITEX Regal Urinal is perfectly suited to areas requiring optimal resistance to vandalism such as public toilets, night clubs, pubs and sports pavilions. Supplied with a concealed rear inlet and incorporating a stylish appearance the Regal is also a fine addition to a bathroom that requires high quality, modern looking sanitary fixtures. The Regal is also available as an Auto Flush model that includes a microwave sensor activated flushing device that is fully concealed inside the wall cavity above the urinal (Smart Sensor Flush). WaterMark and WELS certified as required by plumbing regulations and government legislation.

Preparation and Completion Notes

Britex urinals are approved for use as per the accompanying certifications and can be coupled with cisterns, flush valves & sensor flushing systems according to specific model requirements. It is the installer's responsibility to ensure that the urinal is installed in accordance and to the regulations of the residing governing authority and all applicable plumbing code regulations. Britex Regal Urinal Pods are fitted with a ½ BSP water inlet and a 50mm waste outlet.

As the urinal is to be fixed to the rear wall, ensure that the substructure will provide sufficient support for the urinal. Complete any reinforcement works as necessary and provide noggins where required. Use appropriate anchors suitable for use with the substructure to fix the urinal to the wall surface. Protect the surface of the product during the installation process. Do not remove any PVC coatings that may have been applied to the surface until the product has been commissioned and ready to be used.

UR Drawings

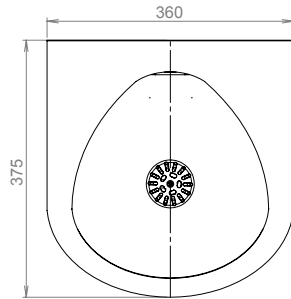
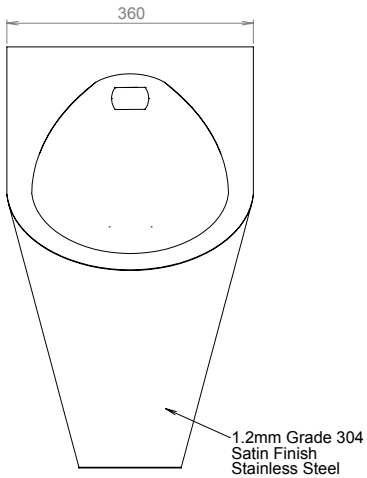
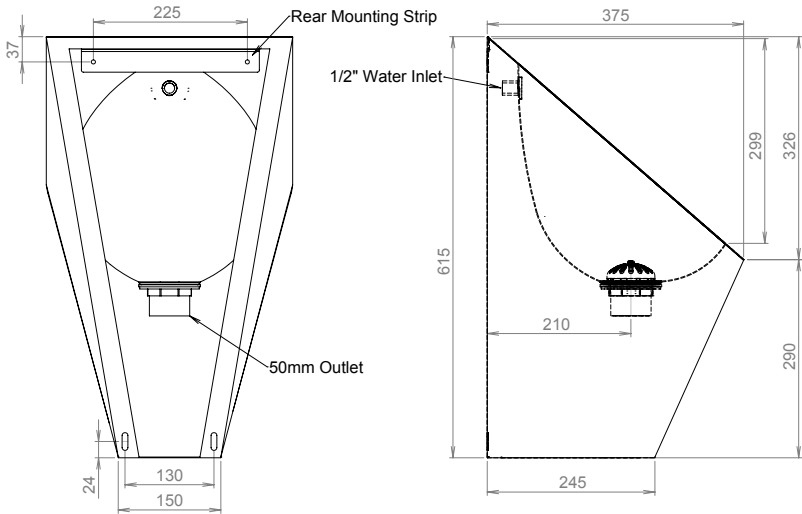

Installation Instructions

1. The box should have the following components in it, the UR or URAM unit that includes the 50mm waste, a joggle strip. Dimension from finished floor to front edge/rim of urinal. The suggested mounting heights for Adults is 610mm and for Juniors 510mm. See figure (A)

Note: Heights are suggestions only, subject to suitability of users for each individual project.

2. The URAM model comes with an automatic sensor flushing device FSM1. Ensure you read the installation in the FSM1 box on how to mount and adjust.

3. For recommended mains plumbing please see figure (B). We suggest installing a Backflow Prevention device according to AS 3500.1 section 4.4.

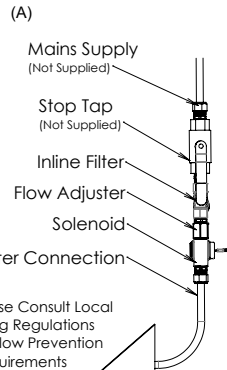
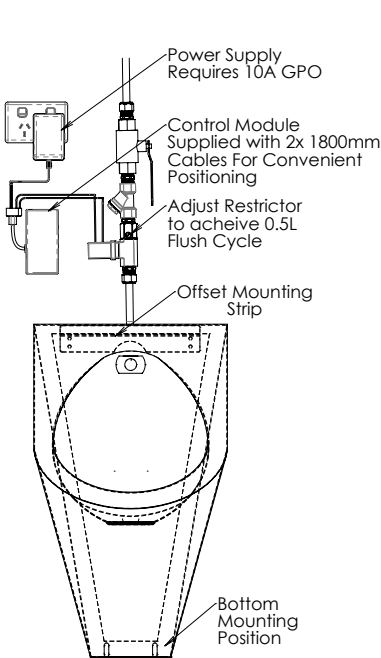
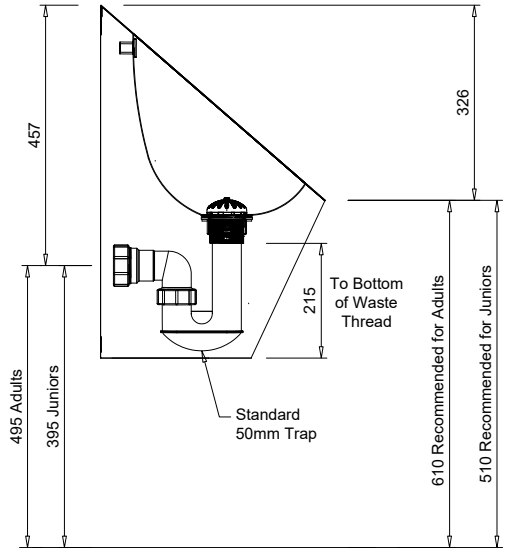

(B)

Installation Instructions

1. The box should have the following components in it, the UR or URAM unit that includes the 50mm waste, a joggle strip. Dimension from finished floor to front edge/rim of urinal. The suggested mounting heights for Adults is 610mm and for Juniors 510mm. See figure (A)

Note: Heights are suggestions only, subject to suitability of users for each individual project.

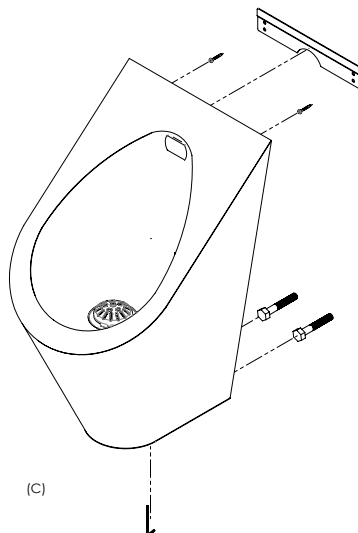

Spare Parts



FSM1
Smart Saniflush Sensor System



74-11-0028
Urinal Waste Outlet with Dome Cover 50 x 45mm G304

Care and Maintenance

Cleaning: The coil at the front of the unit and the vents on the side must be kept clean from dust and lint. Regular checks of the unit should be conducted on a weekly basis and cleaning carried out as necessary by dusting with a soft brush and/or vacuuming. A damp cloth can be used to wipe the exterior cover down. Excessive build up of foreign material will result in poor ventilation, causing the compressor to overheat and drinking water to increase in temperature. High pressure hoses and water jets should never be used to clean chiller units.

Stainless steel products should be kept clean at all times. The secret to stainless steel's ability to maintain a high quality finish and promises of a long life expectancy is the invisible chromium-oxide film that sits on the surface and protects the steel beneath. To maintain this film it is essential that the surface remains clean and in constant contact with oxygen. If this film is penetrated (either by abrasion or chemically) and dirt, liquid, grime contaminants embed themselves in these micro chasms for an extended period of time, the chromiumoxide film will not be able to regenerate and the steel below will eventually become damaged and discoloured.

What we recommend for general cleaning and maintenance:

Cleaning Materials:

- A soft cloth
- A soft-bristled brush
- A natural or artificial sponge

Cleaning Solutions:

- Hand washing soap / soft water solution
- Mild soap / soft water solution
- White vinegar / soft water solution

It is recommended that general cleaning of stainless steel surfaces be carried out weekly, or as soon as a build up of surface media has been observed. To clean, simply wash stainless steel surfaces with, warm, diluted, mild soapy water using a cloth or soft bristled brush. Once all dirt, oil and grime is removed, rinse thoroughly with

clean water and wipe dry.

Do NOT - use a metal brush or steel wool to clean stainless steel. Ever. These tools will scratch the surface as well as potentially leave behind steel fragments that can go rusty and cause the stainless to discolour. Using these materials will void the warranty.

Do NOT - use scourers of any kind that have previously been used on ordinary steel. Microscopic steel fibers transferred onto stainless steel can cause considerable damage to the surface and will void the warranty.

Do NOT - use abrasive cleaning brushes, pads or agents on highly polished finishes

Do NOT use harsh cleaners that contain powerful acidic or alkaline chemicals such as hydrochloric acid and sodium hydroxide that will damage the surface. Any water coming into contact with stainless steel, particularly cleaning solutions, should have zero chloride content as even minute amounts can cause damage. Using these cleaners will void any product warranty.

Do NOT - use chlorinated sanitizers, cleansers or bleach of any kind. Using these substances will void the warranty. Despite some cleaners displaying the text, 'Suitable for Toilets and Urinals' this is more likely in reference to ceramic/vitreous China products and use of these cleaners can damage stainless steel and will void the warranty.

Do NOT - use brick cleaning liquids that contain hydrochloric acid anywhere near stainless. If cement needs to be removed from stainless (before it sets), a mixture of hot water and 25% vinegar or 10% phosphoric acid can be effective. Once cleaned, the surface should then be neutralised with dilute ammonia or sodium bicarbonate then rinsed and dried

Warranty

The BRITEX product is backed by our manufacturer's warranty available for download from our website at www.britex.com.au. We expressly warrant that the product is free from operational defects in workmanship and materials for the warranty period indicated on the schedule in the manufacturer's warranty. During the warranty period, BRITEX will repair or replace any defective products manufactured by BRITEX at no charge, provided that the terms of the manufacturer's warranty are followed.

This warranty is the only warranty given by BRITEX, and we expressly disclaim all other warranties, including but not limited to implied warranties of merchantability and fitness for a particular purpose. This warranty represents the sole and exclusive remedy for breach of warranty, and BRITEX shall not be liable for any incidental, special, or consequential damages, including lost profits, labor charges, delays, vandalism, negligence, fouling caused by foreign material, damage from adverse water conditions, chemical, electrical or any other circumstances beyond BRITEX's control.

This warranty shall be void if the product is abused, misused, improperly installed, maintained, or altered. By purchasing our product, you agree to these terms and conditions. We appreciate your business and look forward to providing you with high-quality products and services.



MELBOURNE
Britex Place Mira Crt
Bundoora VIC 3083
t (03) 9466 9000
e vic@britex.com.au

SYDNEY
16 Northumberland Drv
Taren Point NSW 2229
t (02) 9531 2100
e nsw@britex.com.au

PERTH
Unit 1/8 Principal Link
Malaga WA 6090
t (08) 9249 5464
e wa@britex.com.au

BRISBANE
19 Manilla St
East Brisbane QLD 4169
t (07) 3363 2400
e qld@britex.com.au

ADELAIDE
The Britex Group
SA State Office
t 1300 764 744
e sa@britex.com.au