

DSR-2 | DSRR-2

Accessible Twin Round Drinking Fountain

Installation Guide

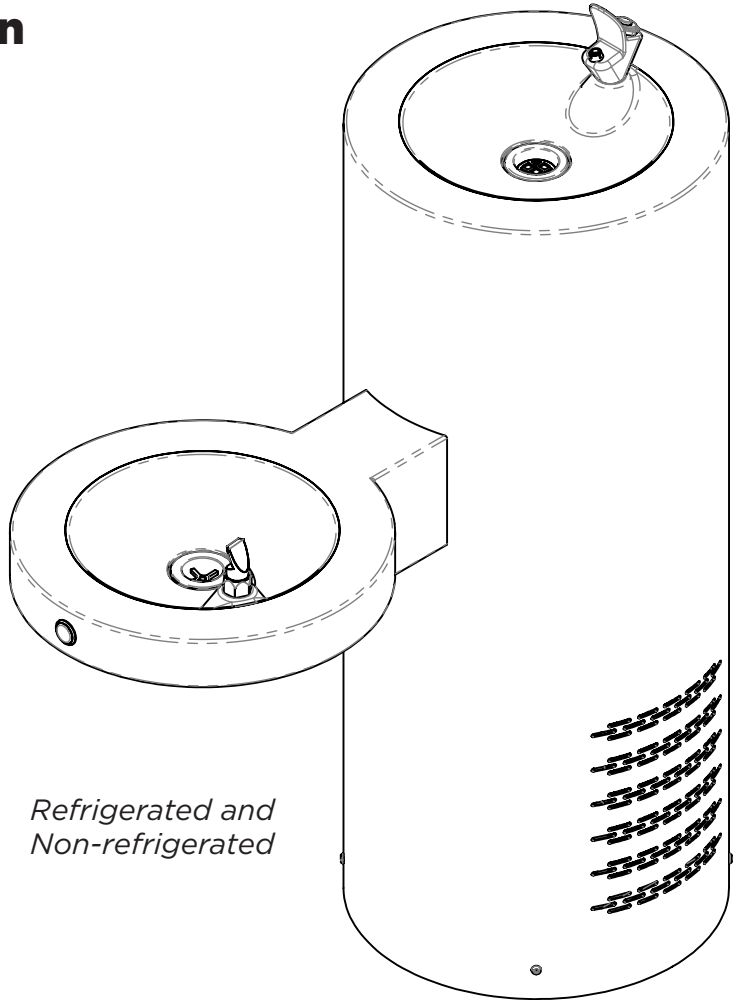

*Refrigerated and
Non-refrigerated*



MELBOURNE
Britex Place Mirra Crt
Bundoora VIC 3083
t (03) 9466 9000
e vic@britex.com.au

SYDNEY
16 Northumberland Drv
Taren Point NSW 2229
t (02) 9531 2100
e nsw@britex.com.au

PERTH
Unit 1/8 Principal Link
Malaga WA 6090
t (08) 9249 5464
e wa@britex.com.au

BRISBANE
19 Manilla St
East Brisbane QLD 4169
t (07) 3363 2400
e qld@britex.com.au

ADELAIDE
The Britex Group
SA State Office
t 1300 764 744
e sa@britex.com.au

IMPORTANT

ALL SERVICE TO BE PERFORMED BY AN AUTHORISED SERVICE PERSON

Installation of this unit must be in accordance with AS/NZS 3500.1, AS/NZS 3500.2, the PCA and the local regulatory requirements. Water and/or electrical supply conditions must comply to national or state requirements and standards. Failure to comply shall void the product warranty and may affect the performance of the product. For further support and after-sales care, please contact Britex.

WARNING

WHEN INSTALLATION IS COMPLETE, ENSURE THESE INSTRUCTIONS REMAIN INSIDE THE PLASTIC BAG PROVIDED WITH THE UNIT FOR FUTURE REFERENCE

About

The BRITEX Stainless Steel Accessible Twin Round Drinking Fountain is supplied complete with Watermarks certified Drink Safe™ low lead bubblers, piezo activated on the accessible end and heavy-duty push-button bubbler on the standard end. Manufactured from 1.2mm commercial grade 304 stainless steel the Drinking Fountain is freestanding and supplied with 40mm waste outlet. It is secured to the ground below with a fixing plate inside the base and is suitable for public reserves and sporting clubs. A flush mounted service hatch provides access for installation and maintenance requirements. A built-in refrigeration unit that provides instant chilled water is optional (refrigerated model DSRR-2) as well as a bottle filler option.

Preparation and Completion Notes

Contractors please note: Ideally, stainless steel drinking fountain should be installed after all other building activities that could cause contamination to the surface of the stainless steel have been completed.

These activities include:

Using proprietary building mortar removers containing hydrochloric acid. Welding, cutting and grinding that may 'spray' carbon steel and iron particles onto the stainless-steel surface.

1. Remove drinking fountain from box packaging and inspect for any damage before beginning installation process. Do not remove the protective film from the stainless steel at this stage.
2. Confirm all requested details are correct.
3. If drinking fountain is damaged in transit or if any details are not as requested, do not install the trough. Notify Britex immediately.

Technical Parameters

Inlet Connection	1/2" BSP Male along with other parts as stipulated in the drawing
Recommended Inlet Pressure	350 kPa
Maximum Inlet Pressure	500 kPa
Water Supply Temperature Limitations	4-15°C

DSR-2 Drawing

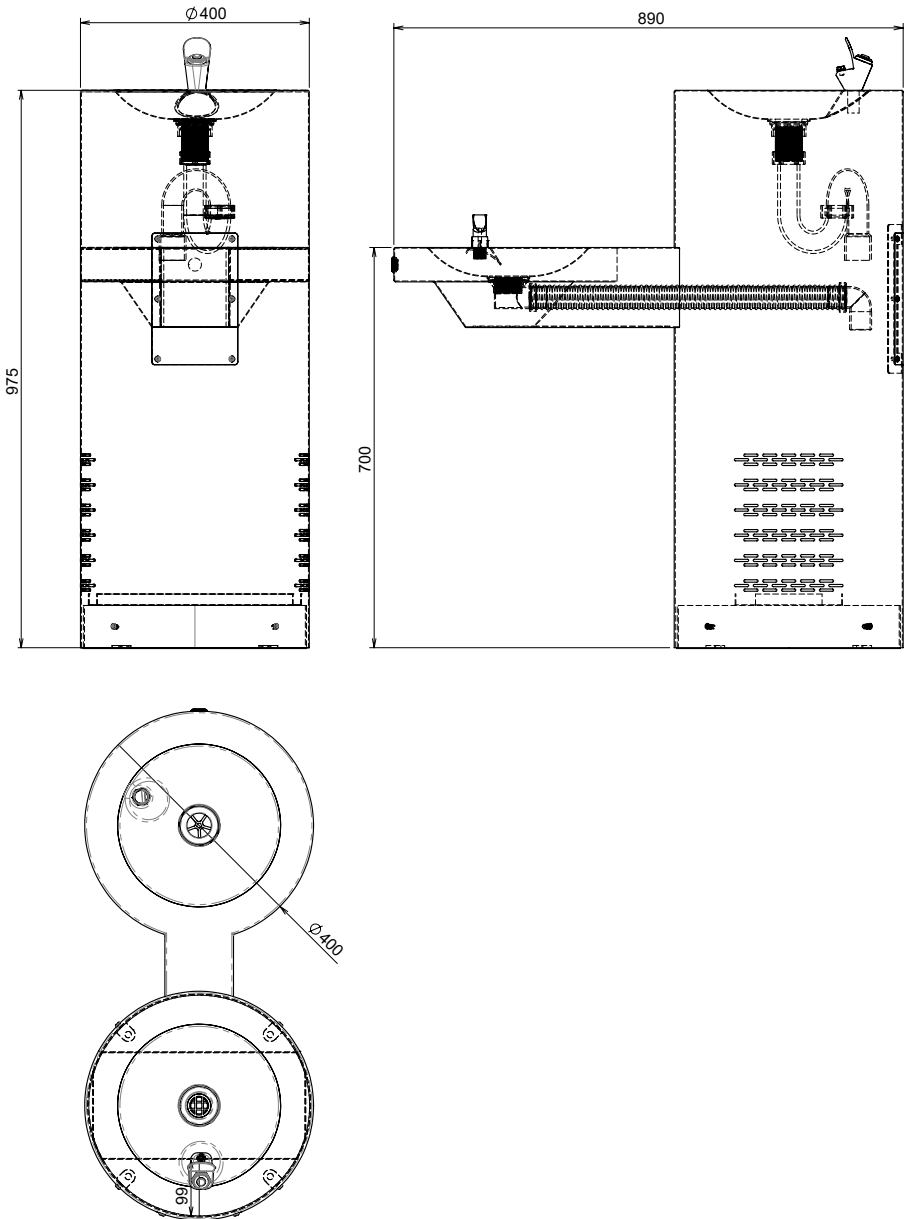

Installation Instructions

1. Mark the area on the floor that the drinking fountain will be mounted too.
2. Remove the fixed base frame that is at the bottom of the unit.
3. Mark the holes on the surface to which you would like to place the unit on.
4. Ensure all supply lines are flushed thoroughly to remove debris prior to the installation. Strainers are recommended if debris is an ongoing problem.
5. Drill the holes and place suitable dyna-bolts to secure the unit. These are 11m in diameter. Tighten these according.
6. Once the base plate is in position then the plumbing components can be installed for the waste and the bubbler.
7. The waste outlet will need to go under the DSR-2 or DSRR-2 and through the ground to the services that are supplied.
8. Once this is achieved then place the shroud on top of the base and use the four fixing holes to attach both together down the bottom of the unit.

For refrigerated unit:

Once the base plate with the chiller is fixed into position, then the plumbing components can be installed for the waste and the bubbler. (Chiller must be installed vertically)

For the DSRR-2, the refrigeration unit should already be installed in the unit.

(Refer to DSRR-2 Assembly Diagram)

1. The refrigeration unit should be housed within the DSRR-2.
2. When running the services these can go on either side of the drinking fountain.
3. Ensure there is a 10-amp standard power outlet to which the 2m 240v cable with the 3 pin plug from chiller will be going into.

DSR-2 Assembly Diagram

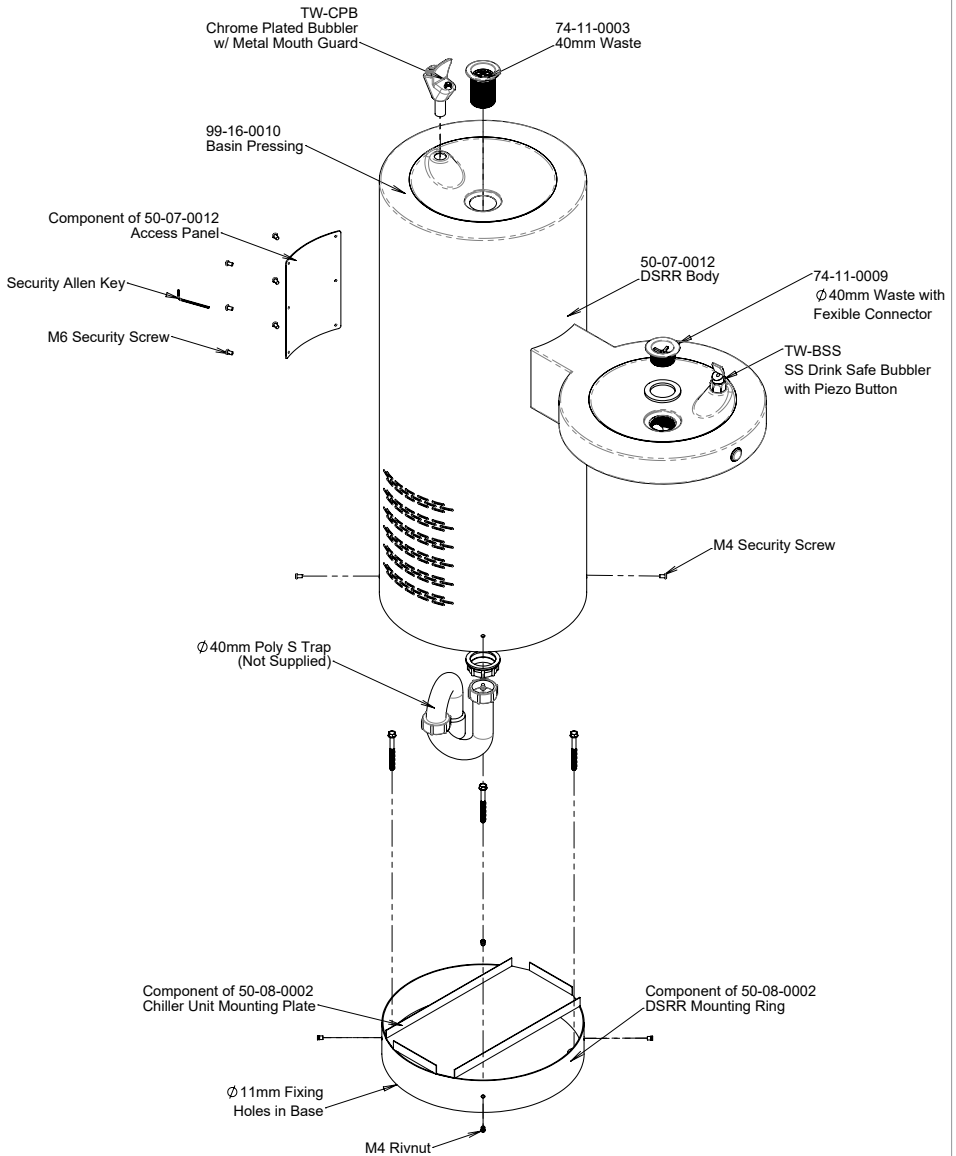

Refer to next page for DSRR-2
(Refrigerated) Assembly Diagram

DSRR-2 Assembly Diagram

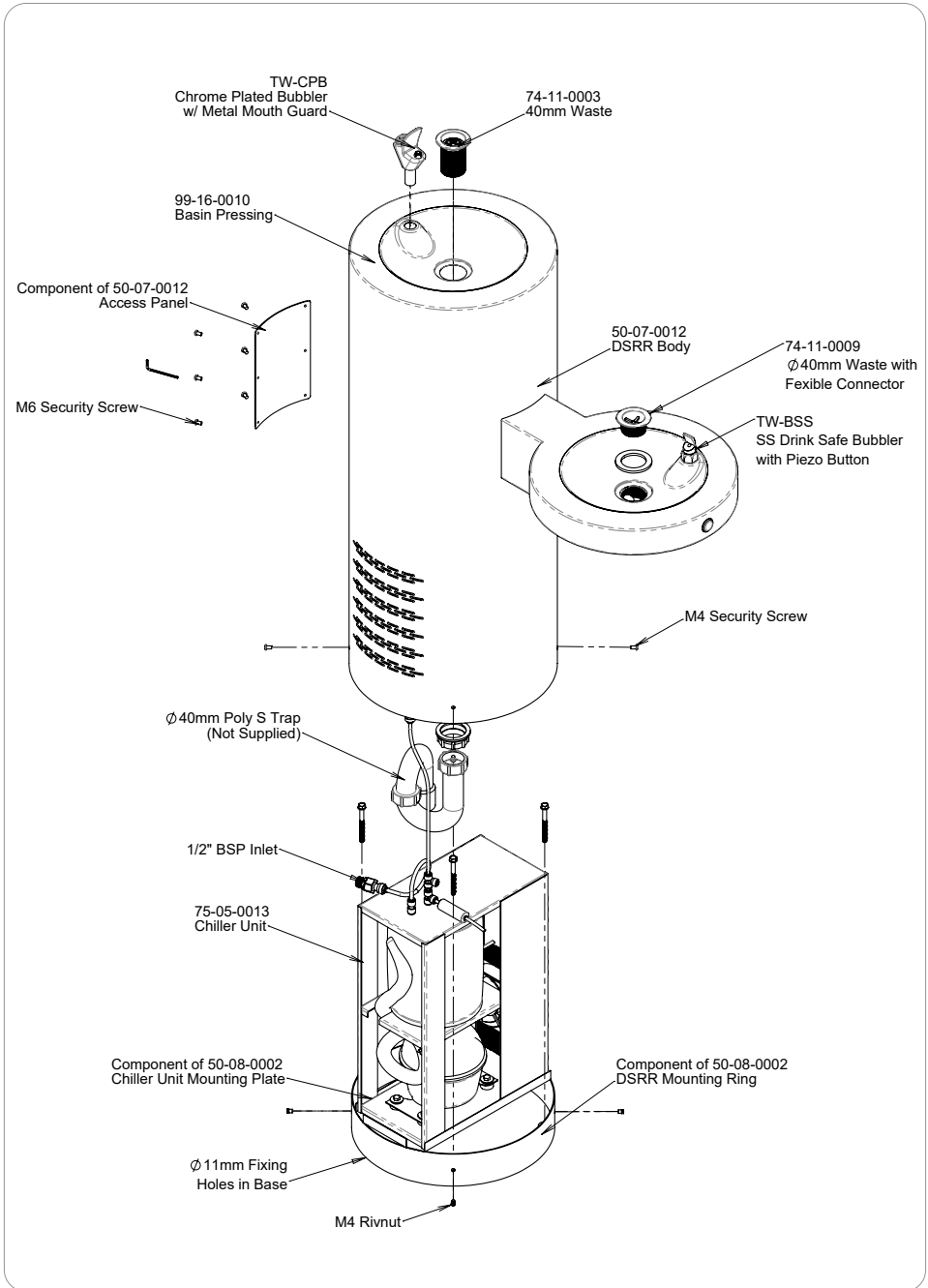

Specifications for CWU-INT Chiller Unit

	CWU - INT
Height	485 mm
Length	335 mm
Width	185 mm
Dry Weight	15.4 kg
Water Tank Capacity	3.6 Litres
Initial Draw Off	4.5 Litres
Water Tank Safety Pressure Relief Valve	700 kPa
Litres per minute of Chilled Water @ 350kPa	15 Litres per hour cold water supply (14 min recovery time)
Compressor	Hermetically sealed with automatic over load
Condenser	Fan assisted
Temperature Control	Capillary controlled factory pre-set thermostat
Thermostat Pre-Set	5 Degrees Celsius (+2)
Power Supply	10 amp power cable and plug
Capacity	1 / 6 HP
Power	165 Watts
Optimum Ambient Operating Temperature	2 - 30 Degrees Celsius
Incoming Water Temperature	17 Degrees Celsius
Chilled to	8 - 10 Degrees Celsius
Minimum Working Pressure	200 kPa
Maximum Working Pressure	800 kPa
Water Inlet	6 mm PE Push in Fitting
Water Outlet	6 mm PE Push in Fitting
Optimum Quantity of Serviced Taps/Bubblers	2
Chilled Cups per Hour (Cup size 175ml)	85

Troubleshooting and Maintenance

SYMPTOM	CAUSES	ACTION
No Water	Water supply	Check main supply
Water not cold	<ul style="list-style-type: none"> Loss of gas Failed fan 	Contact manufacturer
	No power supply	Check and test power supply
	Poor ventilation	Clean cabinet louvers (if fitted) and condenser fins. These units need ventilation

- **Cleaning:** The coil in front of the unit must be kept clean. Check on a regular basis i.e., weekly and should be dusted and vacuumed. The vents on the side of the unit should be free from dust or lint and checked on a regular basis. The cover itself should be wiped over with a damp cloth.
- When servicing/cleaning the unit **please be aware** that the unit is pressurised and contains gas.

Troubleshooting Drinking Fountain

SYMPTOM	CAUSES	ACTION
No Water	Water supply	Check main supply
Leaking waste pipe	Crack in pipe	Contact plumber

Troubleshooting for Manual Push Button Bubblers

PROBLEM	CAUSES	ACTION
Inconsistent flow	Blocked top assembly	Remove top assembly and clean
Water is not flowing from tap	Water is turned off	Turn on water
Continuous flow	Top assembly loose or internally obstructed or damaged	Remove top assembly, clean with water and re-grease spindle if required
Button hard to press	The mains pressure may be too great	Reduce to below 500kPa (70PSI). Regrease spindle if required

Troubleshooting for CWU-INT

SYMPTOM	CAUSES	ACTION
No Water	Water supply	Check main supply
Water not cold	<ul style="list-style-type: none"> • Loss of gas • Failed fan 	Contact manufacturer
	No power supply	Check and test power supply
	Poor ventilation	Clean cabinet louvers (if fitted) and condenser fins. These units need ventilation

How to Activate the Piezo Button



- Press the button once to activate.
- The water will flow for the set duration and turn off automatically.
- Alternatively press the button at any time to turn off.

DO NOT OPERATE PIEZO FOR 20 MINUTES IF YOU HAVE UNPLUGGED AND REPLUGGED THE BATTERY. IF SO, THEN YOU MUST FOLLOW THE RE-PROGRAMMING STEPS SHOWN IN TROUBLE SHOOTING.

Troubleshooting

SYMPTOM	CAUSES	ACTION
Inconsistent flow	Blocked flow regulator screw	Remove flow regulator screw and clean
Water is not flowing from tap	Water is turned off	Turn on water
	Blocked flow regulator	Remove regulator screw and clean
Rate of flow inadequate	The flow regulator screw may not be adjusted correctly	Remove blanking screw and adjust flow regulation screw as described above.

If the timing of the drinking tap has been changed by unplugging the battery, then please follow the instructions to reset.

To reprogram the taps manually, please follow these steps:

1. Disconnect the power
2. Connect the power
3. Press the button 4x times
4. Wait 5 seconds after which the water will flow and then stop automatically.
5. Press the button 5 times
6. Water will start to flow, after the desired flow duration is achieved press the button to set flow duration time

Note: It's crucial not to interact with the piezo for 20 minutes after programming or reconnecting to power to ensure the settings are locked in.

Spare Parts



TW-CPB

Drink Safe™ Push Button Drinking Bubbler Tap. Manufactured using high quality DZR solid brass with less than 0.25% lead content* Vandal Resistant, hygienic and sturdy, perfect for drinking fountains in public amenities, schools and councils.



TW-BF-HF

Hob Mounted Lead Safe Fixed Spout Gooseneck Bottle Filler - Manufactured using high quality DZR solid brass with less than 0.25% lead content*



CWU-INT

- This unit **MUST** be installed in a **Vertical Orientation**
- This unit **MUST** be installed with a **Pressure Relief Valve (supplied)**
- This unit **MUST** be installed with **Ventilation**



PRV

Pressure Relief Valve for CWU-INT

Care and Maintenance

Cleaning: The coil at the front of the unit and the vents on the side must be kept clean from dust and lint. Regular checks of the unit should be conducted on a weekly basis and cleaning carried out as necessary by dusting with a soft brush and/or vacuuming. A damp cloth can be used to wipe the exterior cover down. Excessive build up of foreign material will result in poor ventilation, causing the compressor to overheat and drinking water to increase in temperature. High pressure hoses and water jets should never be used to clean chiller units.

Stainless steel products should be kept clean at all times. The secret to stainless steel's ability to maintain a high quality finish and promises of a long life expectancy is the invisible chromium-oxide film that sits on the surface and protects the steel beneath. To maintain this film it is essential that the surface remains clean and in constant contact with oxygen. If this film is penetrated (either by abrasion or chemically) and dirt, liquid, grime contaminants embed themselves in these micro chasms for an extended period of time, the chromiumoxide film will not be able to regenerate and the steel below will eventually become damaged and discoloured.

What we recommend for general cleaning and maintenance:

Cleaning Materials:

- A soft cloth
- A soft-bristled brush
- A natural or artificial sponge

Cleaning Solutions:

- Hand washing soap / soft water solution
- Mild soap / soft water solution
- White vinegar / soft water solution

It is recommended that general cleaning of stainless steel surfaces be carried out weekly, or as soon as a build up of surface media has been observed. To clean, simply wash stainless steel surfaces with, warm, diluted, mild soapy water using a cloth or soft bristled brush. Once all dirt, oil and grime is removed, rinse thoroughly with

clean water and wipe dry.

Do NOT – use a metal brush or steel wool to clean stainless steel. Ever. These tools will scratch the surface as well as potentially leave behind steel fragments that can go rusty and cause the stainless to discolour. Using these materials will void the warranty.

Do NOT – use scourers of any kind that have previously been used on ordinary steel. Microscopic steel fibers transferred onto stainless steel can cause considerable damage to the surface and will void the warranty.

Do NOT – use abrasive cleaning brushes, pads or agents on highly polished finishes

Do NOT use harsh cleaners that contain powerful acidic or alkaline chemicals such as hydrochloric acid and sodium hydroxide that will damage the surface. Any water coming into contact with stainless steel, particularly cleaning solutions, should have zero chloride content as even minute amounts can cause damage. Using these cleaners will void any product warranty.

Do NOT – use chlorinated sanitizers, cleansers or bleach of any kind. Using these substances will void the warranty. Despite some cleaners displaying the text, 'Suitable for Toilets and Urinals' this is more likely in reference to ceramic/vitreous China products and use of these cleaners can damage stainless steel and will void the warranty.

Do NOT – use brick cleaning liquids that contain hydrochloric acid anywhere near stainless. If cement needs to be removed from stainless (before it sets), a mixture of hot water and 25% vinegar or 10% phosphoric acid can be effective. Once cleaned, the surface should then be neutralised with dilute ammonia or sodium bicarbonate then rinsed and dried

Warranty

The BRITEX product is backed by our manufacturer's warranty available for download from our website at www.britex.com.au. We expressly warrant that the product is free from operational defects in workmanship and materials for the warranty period indicated on the schedule in the manufacturer's warranty. During the warranty period, BRITEX will repair or replace any defective products manufactured by BRITEX at no charge, provided that the terms of the manufacturer's warranty are followed.

This warranty is the only warranty given by BRITEX, and we expressly disclaim all other warranties, including but not limited to implied warranties of merchantability and fitness for a particular purpose. This warranty represents the sole and exclusive remedy for breach of warranty, and BRITEX shall not be liable for any incidental, special, or consequential damages, including lost profits, labor charges, delays, vandalism, negligence, fouling caused by foreign material, damage from adverse water conditions, chemical, electrical or any other circumstances beyond BRITEX's control.

This warranty shall be void if the product is abused, misused, improperly installed, maintained, or altered. By purchasing our product, you agree to these terms and conditions. We appreciate your business and look forward to providing you with high-quality products and services.



MELBOURNE

Britex Place Mirra Crt
Bundoora VIC 3083
t (03) 9466 9000
e vic@britex.com.au

SYDNEY

16 Northumberland Drv
Taren Point NSW 2229
t (02) 9531 2100
e nsw@britex.com.au

PERTH

Unit 1/8 Principal Link
Malaga WA 6090
t (08) 9249 5464
e wa@britex.com.au

BRISBANE

19 Manilla St
East Brisbane QLD 4169
t (07) 3363 2400
e qld@britex.com.au

ADELAIDE

The Britex Group
SA State Office
t 1300 764 744
e sa@britex.com.au