

CHILLED FREESTANDING FOUNTAIN



features and benefits

- Refrigerated
- Freestanding fountain
- Supplied pre-plumbed
- Adjustable leveling feet
- 18 litres per hour flow rate
- Compact size
- Stainless or Powder Coat Finish
- Available with Bubbler and Glass Filler
- Optional Carbon Filter
- Suits schools, offices, sporting clubs and public amenities

about

The *BRITEX Chilled Freestanding Drinking Fountain* is available in a choice in cabinet material (White Powder Finish or Stainless Steel), and optional carbon filter, whilst an inbuilt refrigeration unit provides instant chilled water. Great for offices, schools, pavilions and sporting clubs.

sample spec. text

BRITEX Chilled Freestanding Drinking Fountain - 300 x 320 x 930mm High. Supplied complete with Powder Finish/Stainless Steel cabinet push button bubbler, bottle filler and carbon filter. Unit to be refrigerated - Product Code DFWX-CF

*RED TEXT may denote a variable where one option only is to be selected, a nominal dimension that needs to be specified, or an optional feature that can be removed if not required. Please refer to the back of this page for additional specification details and options.

VISIT BRITEX.COM.AU TO DOWNLOAD BIM FILES, CAD DRAWINGS AND THE MOST CURRENT PRODUCT LITERATURE.



MELBOURNE
Britex Place, Mirra Crt
Bundoora VIC 3083
t (03) 9466 9000
f (03) 9466 9044

SYDNEY
16 Northumberland Drv
Taren Point NSW 2229
t (02) 9531 2100
f (02) 9531 2800

PERTH
Unit 1/8 Principal Link
Malaga WA 6090
t (08) 9249 5464
f (08) 9248 6893

BRISBANE
19 Manilla St
East Brisbane QLD 4169
t (07) 3363 2400
f (07) 3363 2444

ADELAIDE
The Britex Group
SA State Office
t 1300 764 744
f 1300 784 306

britex.com.au | info@britex.com.au | A.B.N 83 004 309 737

CHILLED FREESTANDING FOUNTAIN

PRODUCT CODE

DFW

8.13

FOUNTAINS

#DFW / CHILLED FREESTANDING FOUNTAIN

Code	L/hr	Finish	Bubbler	Glass Filler
DFW3	18	Powder Finish	✓	✓
DFW4	18	Stainless Steel	✓	✓

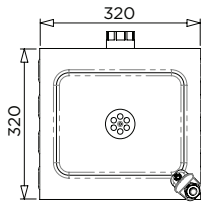

Plan

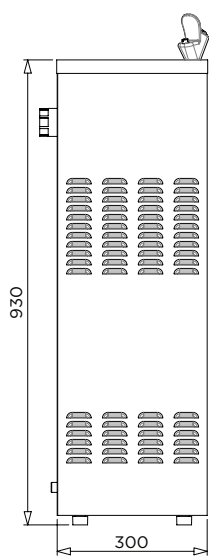

Side Elevation

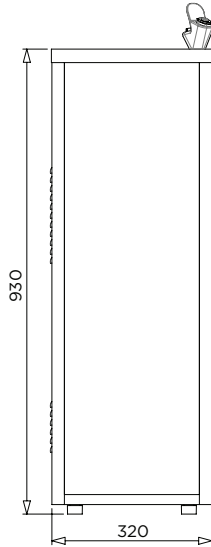

Front Elevation

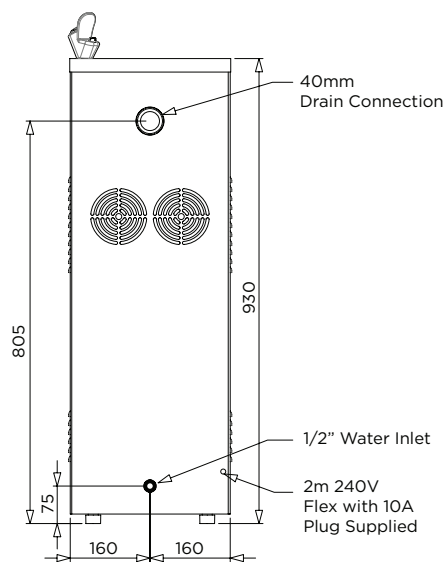

Rear Elevation

MODEL DFW

When specifying this product please include:



- Product Name and Code
- Product Dimensions
- Cabinet Type



- Carbon filter: add '-CF' to code eg:'DFW1-CF'

VISIT BRITEX.COM.AU TO DOWNLOAD BIM FILES, CAD DRAWINGS AND THE MOST CURRENT PRODUCT LITERATURE.

Last Revised June 2017



Due to ongoing research and our commitment to product development, details are subject to change without notice. Details accurate at time of print. Please refer to britex.com.au for the most current product information. Allow +/- 5mm tolerance for dimensions and setouts shown in product literature.

britex.com.au | info@britex.com.au | A.B.N 83 004 309 737

