

DFRE & DFRE-R

Health Club Drinking Fountain & Optional Refrigeration

Installation Guide

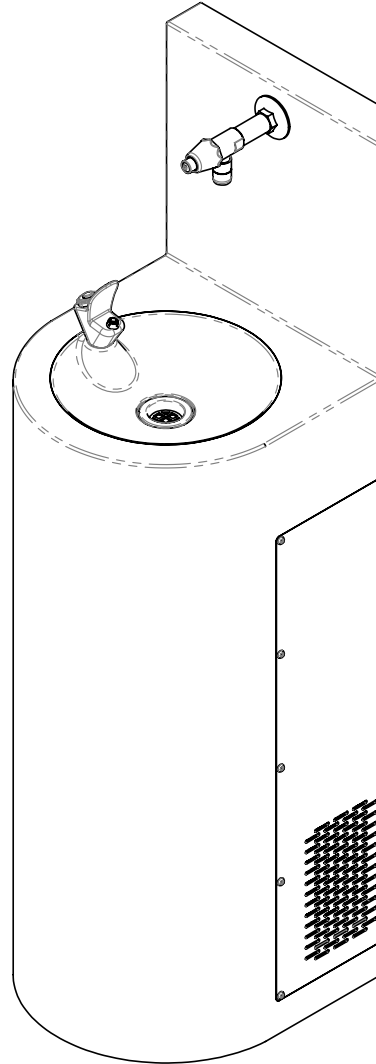

MELBOURNE
Britex Place Mira Crt
Bundoora VIC 3083
t (03) 9466 9000
e vic@britex.com.au

SYDNEY
16 Northumberland Drv
Taren Point NSW 2229
t (02) 9531 2100
e nsw@britex.com.au

PERTH
Unit 1/8 Principal Link
Malaga WA 6090
t (08) 9249 5464
e wa@britex.com.au

BRISBANE
19 Hanilla St
East Brisbane QLD 4169
t (07) 3363 2400
e qld@britex.com.au

ADELAIDE
The Britex Group
SA State Office
t 1300 764 744
e sa@britex.com.au

IMPORTANT

ALL SERVICE TO BE PERFORMED BY AN AUTHORISED SERVICE PERSON

Installation of this unit must be in accordance with AS/NZS 3500.1, AS/NZS 3500.2, the PCA and the local regulatory requirements. Water and/or electrical supply conditions must comply to national or state requirements and standards. Failure to comply shall void the product warranty and may affect the performance of the product. For further support and after-sales care, please contact Britex.

WARNING

WHEN INSTALLATION IS COMPLETE, ENSURE THESE INSTRUCTIONS REMAIN INSIDE THE PLASTIC BAG PROVIDED WITH THE UNIT FOR FUTURE REFERENCE

About

The BRITEX Stainless Steel Health Club Drinking Fountain is supplied complete with a heavy-duty push-button bubbler and wall mounted drink bottle filler. A service hatch in the pedestal provides access for installation and maintenance requirements. Manufactured from 1.2mm commercial grade 304 stainless steel the Drinking Station is secured to the rear wall with an offset bracket and to the ground below. Refrigerated model supplying chilled water available upon request. Suitable for gyms, schools and sporting clubs.

Preparation and Completion Notes

Contractors please note: Ideally, stainless steel drinking fountain should be installed after all other building activities that could cause contamination to the surface of the stainless steel have been completed.

These activities include:

Using proprietary building mortar removers containing hydrochloric acid. Welding, cutting and grinding that may 'spray' carbon steel and iron particles onto the stainless-steel surface.

1. Remove drinking fountain from box packaging and inspect for any damage before beginning installation process.
2. Confirm all requested details are correct.
3. If drinking fountain is damaged in transit or if any details are not as requested, do not install it. Notify Britex immediately within 24 hours of receiving the product.

DPDF Installation Drawing

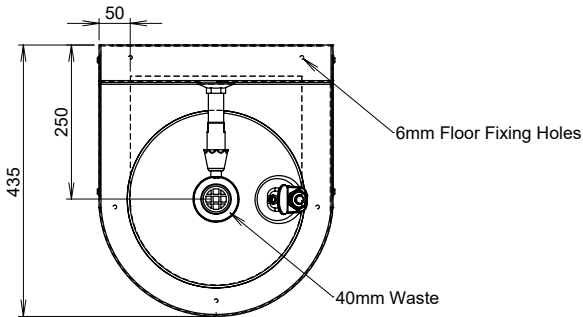
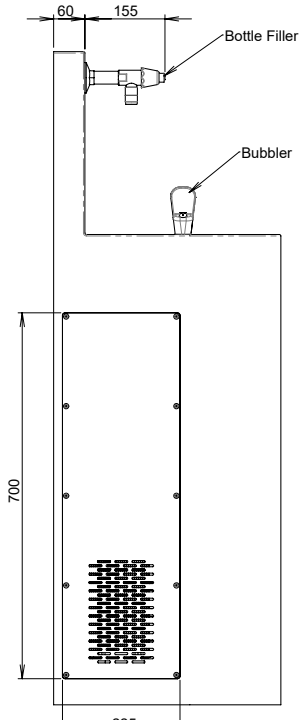
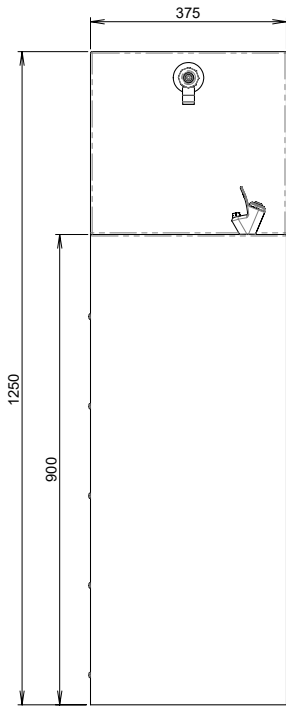

Installation Instructions

- 1.The drinking fountain is pre plumbed out of the box, the refrigeration unit will be integrated already into the base of the unit, if you have chosen that as an added option.
- 2.Prepare the area in which you will be placing the unit into.
- 3.Fountain is secured to ground via five fixing holes (6mm dia.) Britex suggest a bead of silicon be placed all around the back of the unit against the wall. The Plumbing connections and base fixing points are accessed by removing access panel.
- 4.Once the unit is installed, then the 40mm waste outlet can be plumbed. (Trap not supplied).
- 5.Water connections to 1/2" bubbler and bottle filler can then be connected. These will need to be checked to see if they are working to the desired degree.
- 6.Britex suggest an in-line filter to prevent debris fouling outlets is installed to prevent the unit's bubbler and/or bottle filler from malfunctioning.

Note: No need for any special tools to carry out this job.

If you have ordered a refrigeration model, then below is the other steps that need to be carried out.

- 1.The refrigeration unit should be housed within the DFRE, ready to be plumbed to mains. Ensure there is a 10-amp standard power outlet within reach.

Installation Drawing

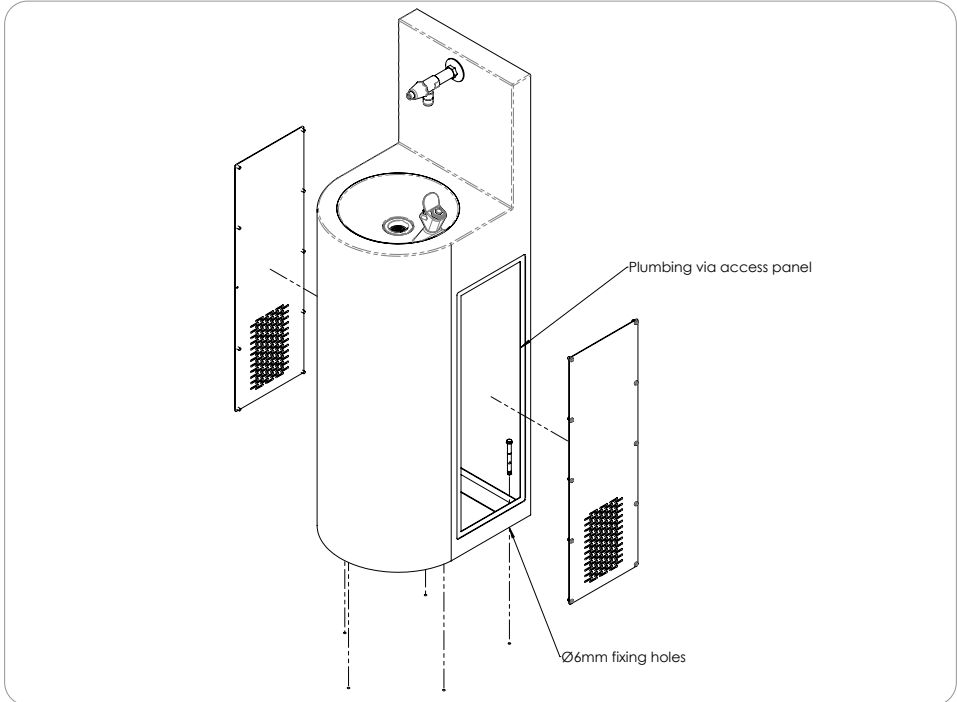

Installation Drawing

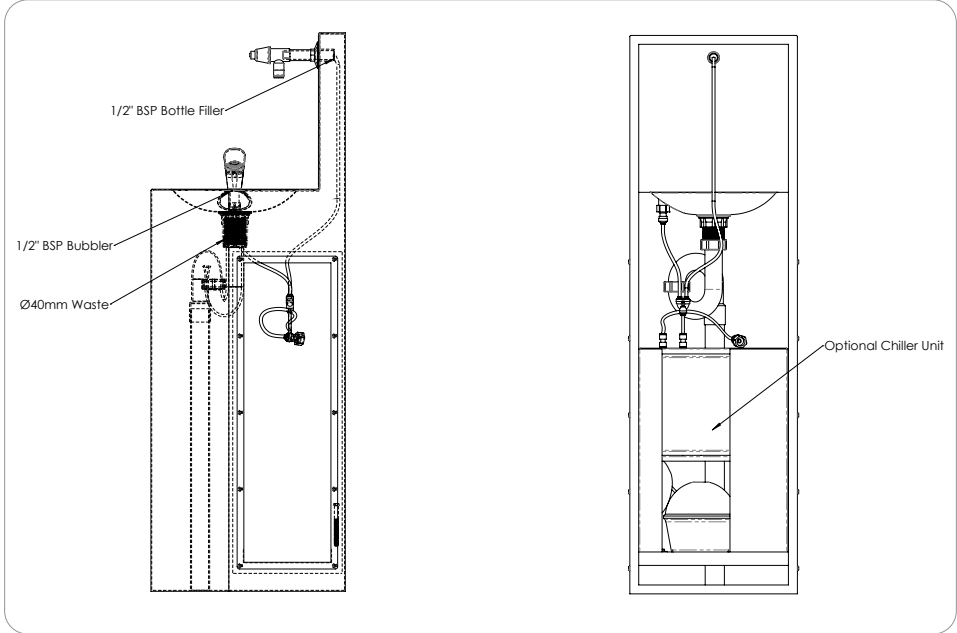

Technical Parameters

Inlet Connection	1/2" BSP Male
Recommended Inlet Pressure	350 kPa
Maximum Inlet Pressure	500 kPa
Outlet Connection	40mm Waste

Troubleshooting

PROBLEM	CAUSES	ACTION
Water Not Cold	- Loss of gas - Failed Fan	Contact manufacturer
Power supply to Chiller unit	No Power Supply	Check and test power supply
Inconsistent flow	Blocked flow regulator screw	Remove flow regulator screw and clean.
Water is not flowing from tap	Water is turned off	Turn on Water

Spare Parts



TW-BF-WE-FB65
Bottle Filler Wall Mounted



TW-CPB
Bubbler Chrome Plated (Low Lead Brass) Drink Safe with Metal Mouth Guard



CWU-INT
Chiller Unit



PRV
Pressure Relief Valve

Care and Maintenance

Stainless steel products should be kept clean at all times. The secret to stainless steel's ability to maintain a high-quality finish and promises of a long-life expectancy is the invisible chromium-oxide film that sits on the surface and protects the steel beneath. To maintain this film, it is essential that the surface remains clean and in constant contact with oxygen. If this film is penetrated (either by abrasion or chemically) and dirt, liquid, grime contaminants embed themselves in these micro chasms for an extended period, the chromium oxide film will not be able to regenerate and the steel below will eventually become damaged and discoloured.

What we recommend for general cleaning and maintenance:

Cleaning Materials:

- A soft cloth
- A soft-bristled brush
- A natural or artificial sponge

Cleaning Solutions:

- Hand washing soap / soft water solution
- Mild soap / soft water solution
- White vinegar / soft water solution

It is recommended that general cleaning of stainless-steel surfaces be carried out weekly, or as soon as a build-up of surface media has been observed. To clean, simply wash stainless steel surfaces with, warm, diluted, mild soapy water using a cloth or soft bristled brush. Once all dirt, oil and grime is removed, rinse thoroughly with clean water and wipe dry.

Warranty

The BRITEX product is backed by our manufacturer's warranty available for download from our website at www.britex.com.au. We expressly warrant that the product is free from operational defects in workmanship and materials for the warranty period indicated on the schedule in the manufacturer's warranty. During the warranty period, BRITEX will repair or replace any defective products manufactured by BRITEX at no charge, provided that the terms of the manufacturer's warranty are followed.

This warranty is the only warranty given by BRITEX, and we expressly disclaim all other warranties, including but not limited to implied warranties of merchantability and fitness for a particular purpose. This warranty represents the sole and exclusive remedy for breach of warranty, and BRITEX shall not be liable for any incidental, special, or consequential damages, including lost profits, labor charges, delays, vandalism, negligence, fouling caused by foreign material, damage from adverse water conditions, chemical, electrical or any other circumstances beyond BRITEX's control.

This warranty shall be void if the product is abused, misused, improperly installed, maintained, or altered. By purchasing our product, you agree to these terms and conditions. We appreciate your business and look forward to providing you with high-quality products and services.



MELBOURNE
Britex Place Mira Crt
Bundoora VIC 3083
t (03) 9466 9000
e vic@britex.com.au

SYDNEY
16 Northumberland Drv
Taren Point NSW 2229
t (02) 9531 2100
e nsw@britex.com.au

PERTH
Unit 1/8 Principal Link
Malaga WA 6090
t (08) 9249 5464
e wa@britex.com.au

BRISBANE
19 Manilla St
East Brisbane QLD 4169
t (07) 3363 2400
e qld@britex.com.au

ADELAIDE
The Britex Group
SA State Office
t 1300 764 744
e sa@britex.com.au