

HEALTH CLUB DRINKING FOUNTAIN



features and benefits

- Includes drink bubbler and bottle filler
- Concealed fixings
- Secured to rear wall and floor
- Grade 304 satin stainless steel
- 40mm waste outlet
- Vandal resistant access hatch
- Refrigerated model available
- Suits gyms, health clubs, schools and sporting clubs

about

The *BRITEX Stainless Steel Health Club Drinking Fountain* is supplied complete with a heavy duty push button bubbler and wall mounted drink bottle filler. A service hatch in the pedestal provides access for installation and maintenance requirements. Manufactured from 1.2mm commercial grade 304 stainless steel the Drinking Station is secured to the rear wall with an offset bracket and to the ground below. Refrigerated model supplying chilled water available upon request. Suitable for gyms, schools and sporting clubs.

sample spec. text

*BRITEX S.S. Health Club Drinking Fountain - 375mm Wide x 1250mm High O/A incorporating 350mm splashback with integrated bottle filler. Supplied complete with 40mm waste outlet, push button bubbler and removable access hatch. **Unit to be refrigerated** - Product Code DFRE-R*

*RED TEXT may denote a **variable** where one option only is to be selected, a **nominal dimension** that needs to be specified, or an **optional feature** that can be removed if not required. Please refer to the back of this page for additional specification details and options.

VISIT BRITEX.COM.AU TO DOWNLOAD BIM FILES, CAD DRAWINGS AND THE MOST CURRENT PRODUCT LITERATURE.



MELBOURNE
Britex Place, Mirra Crt
Bundoora VIC 3083
t (03) 9466 9000
f (03) 9466 9044

SYDNEY
16 Northumberland Drv
Taren Point NSW 2229
t (02) 9531 2100
f (02) 9531 2800

PERTH
Unit 1/8 Principal Link
Malaga WA 6090
t (08) 9249 5464
f (08) 9248 6893

BRISBANE
19 Manilla St
East Brisbane QLD 4169
t (07) 3363 2400
f (07) 3363 2444

ADELAIDE
The Britex Group
SA State Office
t 1300 764 744
f 1300 784 306

britex.com.au | info@britex.com.au | A.B.N 83 004 309 737

HEALTH CLUB DRINKING FOUNTAIN

PRODUCT CODE

DFRE

Ambient Water

DFRE-R

Refrigerated Water

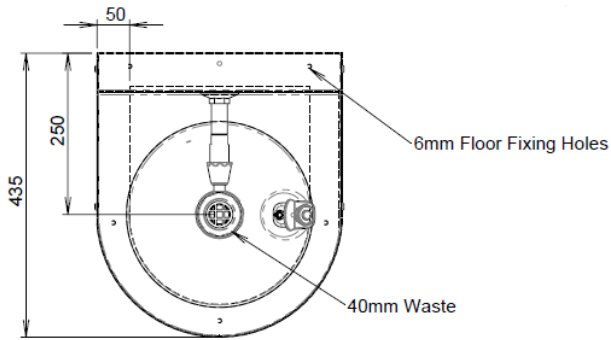

MODEL DFRE-R Plan

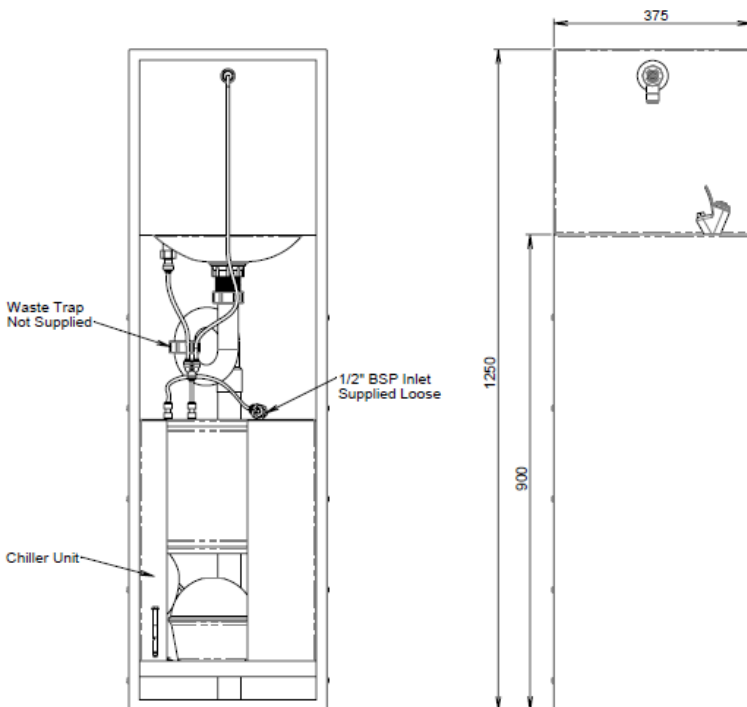

MODEL DFRE-R Rear Elevation and Front Elevation

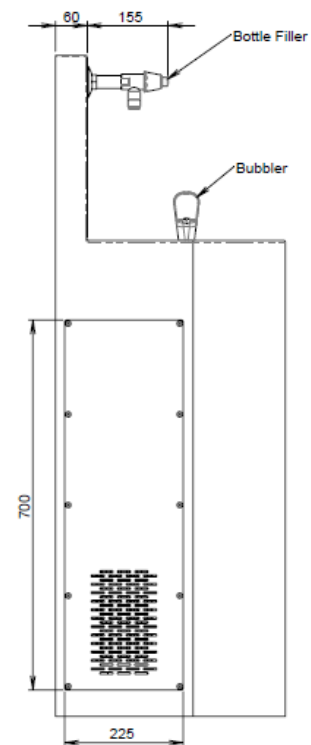

MODEL DFRE-R Side Elevation

When specifying this product please include:

- Product Name and Code
- Product Features

specifying guide

options

- Refrigerated Model available - add R to product code eg DFRE-R

VISIT BRITEX.COM.AU TO DOWNLOAD BIM FILES, CAD DRAWINGS AND THE MOST CURRENT PRODUCT LITERATURE.

Last Revised Apr 2024 | D