

DADO ROUND DRINKING FOUNTAIN WITH HANDS-FREE BOTTLE FILLER

FOUNTAINS



features and benefits

- Modern appearance
- Accessible model
- Integral splashback panel
- Front piezo timed flow lead-safe bubblers (run time 7 secs)
- Hands-free lead-safe bottle filler (run time 20 secs)
- 40mm waste outlets
- Stainless bracket supplied
- Remote refrigeration model available
- Grade 304 satin S.S.
- Concealed Access
- Suits schools, airports, shopping centres and public areas

about

The *BRITEX Stainless Steel Dado Round Drinking Fountain with Hands-Free Bottle Filler* is a stylish, versatile fixture supplied with an accessible drinking station. This unit comes complete with front piezo timed flow lead-safe bubblers, a hygienic hands-free lead-safe bottle filler, splashback panel, waste outlets, mounting bracket and concealed access. Manufactured from commercial grade 304 stainless steel. Refrigerated models are supplied with a separate remote chiller unit for installation within wall cavity.

sample spec. text

BRITEX S.S. Dado Round Drinking Fountain with Hands-Free Bottle Filler - Backing panel to be 600L x 850H. Supplied complete with 40mm waste outlets, front piezo button activated bubblers, hands-free bottle filler **and remote refrigeration unit**. Left hand fountain to be AS1428 compliant - Product Code DDR1-D-R-HFBB

*RED TEXT may denote a **variable** where one option only is to be selected, a **nominal dimension** that needs to be specified, or an **optional feature** that can be removed if not required. Please refer to the back of this page for additional specification details and options.

VISIT BRITEX.COM.AU TO DOWNLOAD BIM FILES, CAD DRAWINGS AND THE MOST CURRENT PRODUCT LITERATURE.



MELBOURNE
Britex Place, Mirra Crt
Bundoora VIC 3083
t (03) 9466 9000
f (03) 9466 9044

SYDNEY
16 Northumberland Drv
Taren Point NSW 2229
t (02) 9531 2100
f (02) 9531 2800

PERTH
Unit 1/8 Principal Link
Malaga WA 6090
t (08) 9249 5464
f (08) 9248 6893

BRISBANE
19 Manilla St
East Brisbane QLD 4169
t (07) 3363 2400
f (07) 3363 2444

ADELAIDE
The Britex Group
SA State Office
t 1300 764 744
f 1300 784 306

britex.com.au | sales@britex.com.au | A.B.N 83 004 309 737

#DDR1-D-HFBB / DADO ROUND WITH HF BOTTLE FILLER

DADO ROUND DRINKING FOUNTAIN WITH HANDS-FREE BOTTLE FILLER

PRODUCT CODE

DDR1-D-HFBF

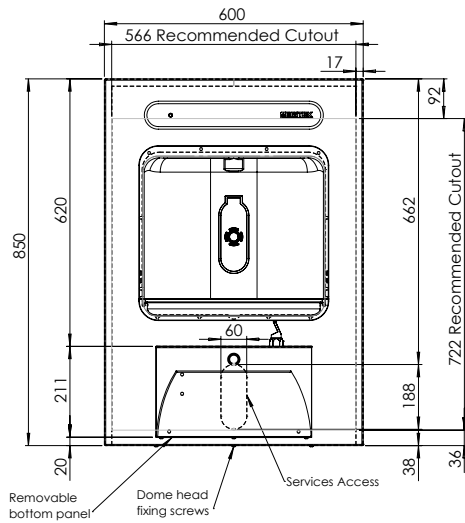

MODEL DDR1-D-HFBF Front Elevation

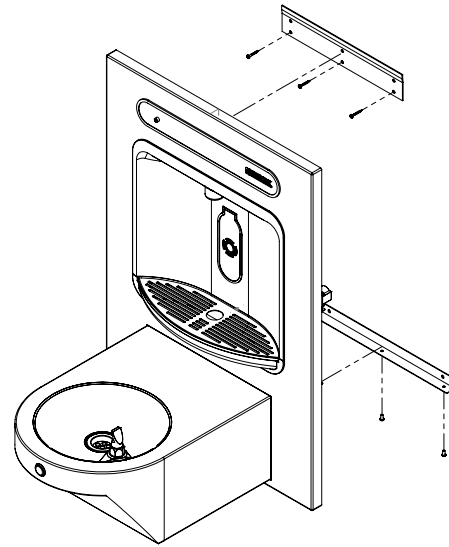

MODEL DDR1-D-HFBF Joggle Strip

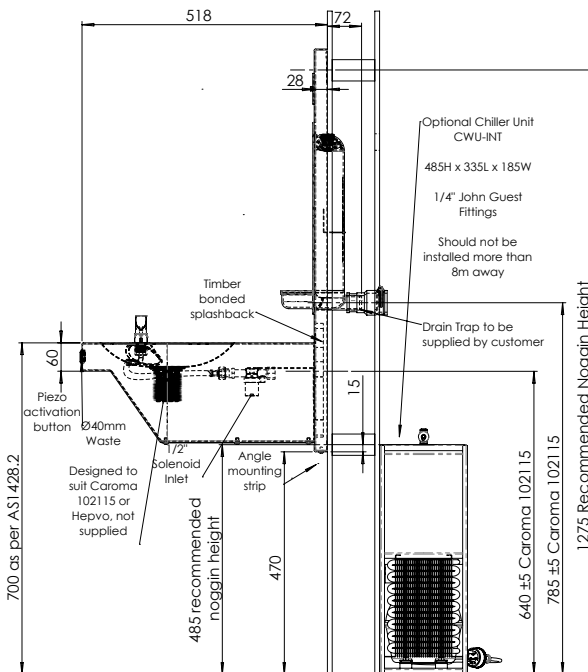

MODEL DDR1-D-HFBF Side

When specifying this product please include:

- Product Name and Code
- Product Dimensions
- Product Features

specifying guide

options

- Refrigerated

VISIT BRITEX.COM.AU TO DOWNLOAD BIM FILES, CAD DRAWINGS AND THE MOST CURRENT PRODUCT LITERATURE.

Last Revised Oct 2023| Rev A



Due to ongoing research and our commitment to product development, details are subject to change without notice. Details accurate at time of print. Please refer to britex.com.au for the most current product information. Allow +/- 5mm tolerance for dimensions and setouts shown in product literature.



britex.com.au | sales@britex.com.au | A.B.N 83 004 309 737

Quality ISO 9001