

SECURITY SOAP HOLDER

FEATURES;

- Vandal proof design.
- Radiused edges.
- No ligature points.
- Contraband-proof.
- Concealed fixings.



BRITTEX

Britex Security Soap Holder comprise a recessed, vandal resistant, one piece unit which can be flush-fit to walls or fixtures.

SSH

123

PRODUCT CODE:

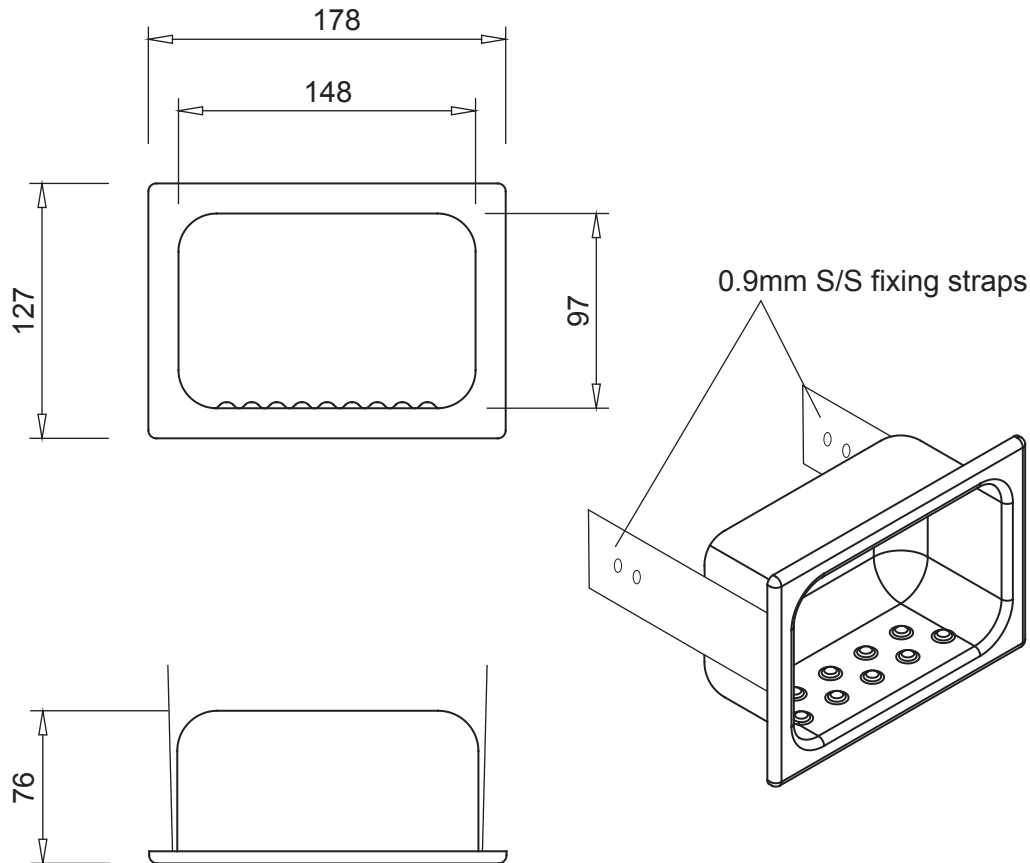
SSH**SPECIFICATIONS**

When specifying this product, please include the following details;

- Product **Name** and **Model No.**

OPTIONS

- Integrated into other Britex units.
- Front fixings.

SSH**Melbourne**

Britex Place, Mirra Court
Bundoora
Victoria 3083
Telephone 1300 764 744
Fax (03) 9466 9044

Sydney

Unit 11, 16-18 Northumberland Rd
Taren Point
New South Wales 2229
Telephone 1300 764 744
Fax (02) 9531 2800



BRITEX
STAINLESS STEEL FABRICATED PRODUCTS

SINCE 1938

www.britex.com.au

e-mail info@britex.com.au

A.B.N. 83 004 309 737

Represented in all states of Australia, throughout Asia and the Pacific Regions.

All product manufacturing by **BRITEX** can be adapted to suit your special application.

Allow 5mm tolerance for setout dimensions given in these drawings. Details accurate at time of print.

As **BRITEX** is always committed to improving on design and quality, it is possible that some details may alter without notice.