

PULL CHAIN CISTERN

FEATURES;

- Heavy duty Stainless Steel case.
- Pull Chain activation.
- Side inlet valve.
- Anti Vandal inspection panel.
- Easy to fit.
- Approved fittings / mechanism.



The **Britex Pull Chain Cistern** is suitable for public amenities, schools and clubs. Supplied with a pull chain and interchangeable inlet valve. Ideal for use with Britex urinals, Slohoppers and pans.

BRITEX

PRODUCT CODE:

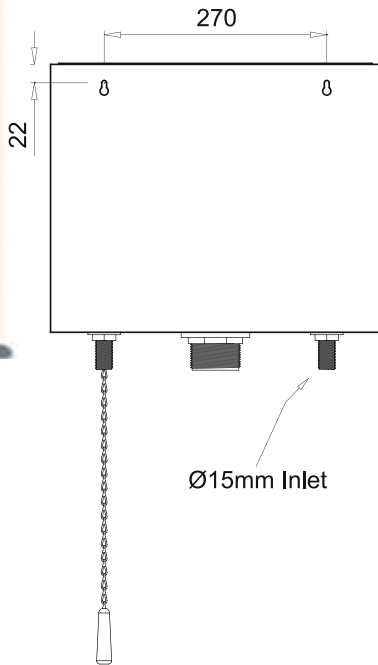
FCP

Front Elevation

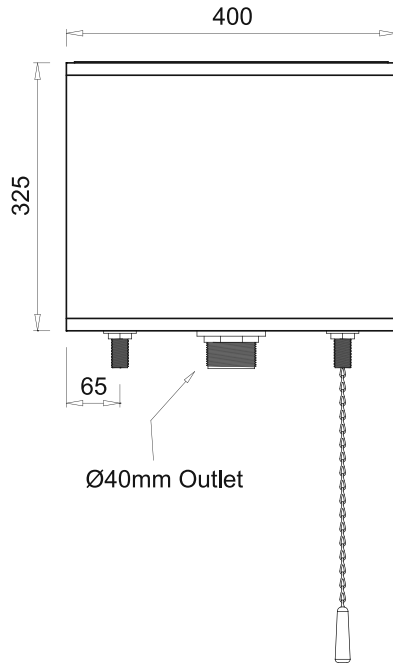

Rear Elevation

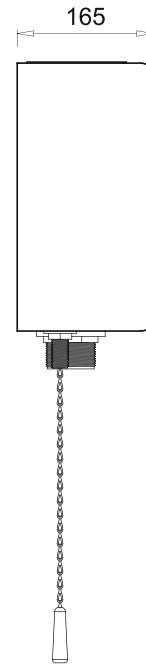

Side Elevation

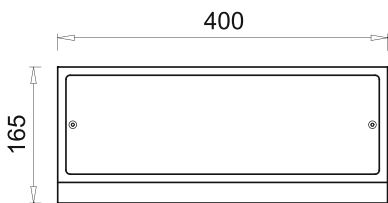

Plan

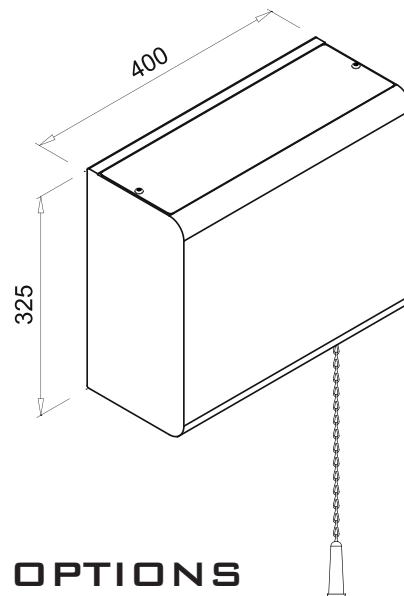
**SPECIFICATIONS**

When specifying this product, please include the following details;

- Product **Name** and **Model No.**

OPTIONS

- Bottom inlet valve.
- Colours.

Melbourne

Britex Place, Mirra Court
Bundoora
Victoria 3083
Telephone (03) 9466 9000
Fax (03) 9466 9044

Sydney

Unit 11, 16-18 Northumberland Rd
Taren Point
New South Wales 2229
Telephone (02) 9531 2100
Fax (02) 9531 2800



BRITEX SINCE 1938

STAINLESS STEEL FABRICATED PRODUCTS

www.britex.com.au

e-mail info@britex.com.au

A.B.N. 83 004 309 737

Represented in all states of Australia, throughout Asia and the Pacific Regions.

All product manufacturing by **BRITEX** can be adapted to suit your special application.

Allow 5mm tolerance for setout dimensions given in these drawings. Details accurate at time of print.

As **BRITEX** is always committed to improving on design and quality, it is possible that some details may alter without notice.