

# MULTIPLE SHOWER BASE

## FEATURES;

- Fully hand made.
- Custom sizes available.
- Available in multiples.



# BRITEX

## BSBM

**BRITEX Multiple Shower Bases** are manufactured from satin finish stainless steel. They are available in multiple cubicle configuration, or as one large shower tray, both sharing a common rear gutter. Multiple shower bases are available in left or right hand outlet configurations.

PRODUCT CODE:

# BSBM

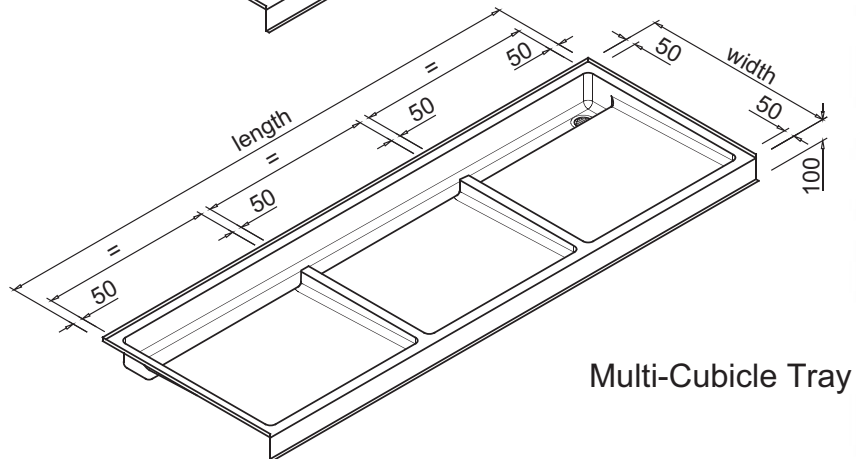
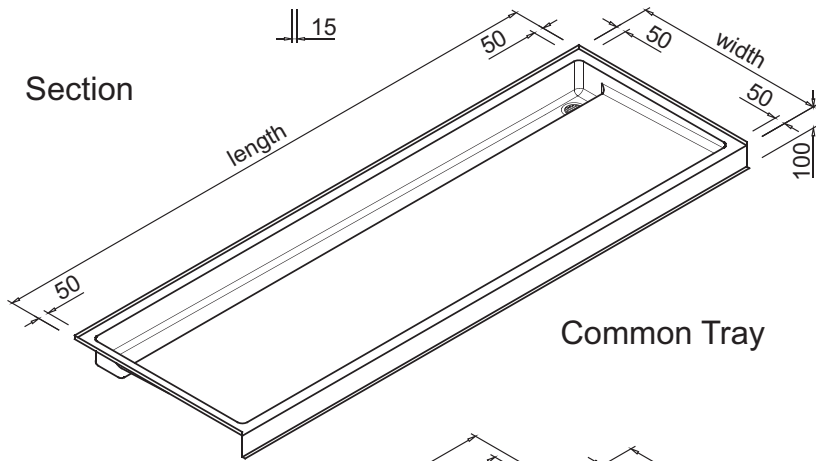
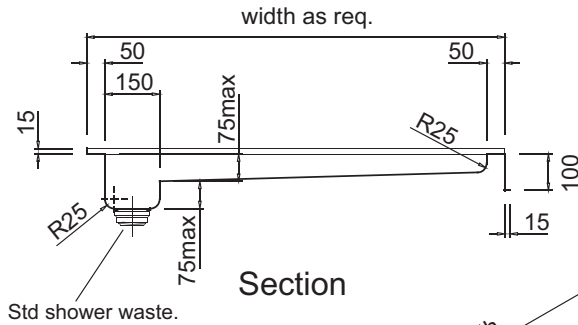

MULTIPLE SHOWER BASES

BSBM

## SPECIFICATIONS

When specifying this product, please include the following details;

- Product **Name** and **Model No.**
- Product **Features.**
- Product **Dimensions.**
- No of **Cubicles.**

**Melbourne**  
 Britex Place, Mirra Court  
 Bundoora  
 Victoria 3083  
 Telephone 1300 764 744  
 Fax (03) 9466 9044

**Sydney**  
 Unit 11, 16-18 Northumberland Rd  
 Taren Point  
 New South Wales 2229  
 Telephone 1300 764 744  
 Fax (02) 9531 2800

## OPTIONS

- Waste position.
- Inset style available.

Represented in all states of Australia, throughout Asia and the Pacific Regions.  
 All product manufacturing by **BRITEX** can be adapted to suit your special application.  
 Allow 5mm tolerance for setout dimensions given in these drawings. Details accurate at time of print.  
 As **BRITEX** is always committed to improving on design and quality, it is possible that some details may alter without notice.



[www.britex.com.au](http://www.britex.com.au)  
 e-mail [info@britex.com.au](mailto:info@britex.com.au)  
 A.B.N. 83 004 309 737